



**SCV VALVE**  
Innovative Valve Solutions®

## Geothermal Valves

THRU CONDUIT EXPANDING & SLAB GATE VALVES • WEDGE GATE VALVES



[www.SCVVALVE.com](http://www.SCVVALVE.com)

# Keepin' it clean!

HARNESS EARTH'S ENERGY





SCV VALVE manufactures some of the most dependable cast steel API 6D Thru Conduit Slab and Expanding Gate Valves and API 600 Wedge Gates in the Geothermal industry. The Thru Conduit Slab & Expanding Gate and Wedge Gate are manufactured and tested in accordance with API standards all designs minimizes pressure drop and turbulence. The mechanical characteristics of the Thru Conduit Slab Gate and Wedge Gate valves are ideal for bi-directional “total flow system open/shut-off” applications.

The SCV design offers many features and options beneficial for geothermal applications making it the most demanded Thru Conduit Gate on the market.

SCV is an API 6A, API 6D monogrammed facility located in Santa Fe, TX operating under the ISO 9001, SCV HSE & Q1 Quality Programs.



SCV Valve’s product lines include commodity valves as well as specialty valves in all sizes, pressure classes & metallurgy; including carbon steel, stainless steel & exotic alloys. The valve types include:

- Thru Conduit Gates - Slab & Expanding Gate Designs
- 3-Piece Trunnion Mounted Balls
- Floating Balls
- Wedge Gates
- Globes
- Full Port Swing Checks
- Piston Checks
- Pressure Balanced Lubricated Plugs

SCV Valve’s high quality standards demand 100% pressure testing of every valve to insure its reliability and full customer satisfaction. We pride ourselves with high quality products, timely deliveries, and competitive prices.

## Company History

The SCV valve brand was established in 1972. The primary focus of the Company was to provide full inline field service for valve maintenance as well as in house valve modifications. While serving the Power Industry, Paper & Pulp, Oil & Gas, and the Petro Chemical Industry; through years of dedication and commitment to quality and service, SCV had become one of the largest full range, field service companies, with a reputation for superior quality.

In the mid 1970s, the SCV brand entered the valve manufacturing industry, primarily serving the Power Industry. Since that time, the SCV brand has expanded its products to cover a broad range of valves. SCV Valve holds the API 6A & API 6D Monogram and API Q1 Quality Management System. The manufacturing facility, sales and projects office is located in Santa Fe, Texas.

## Mission Statement

SCV Valve is committed to consistently providing products that meet or exceed customer and regulatory specifications. SCV Valve aims to enhance customer satisfaction through implementing the highest levels of quality standards while assuring full conformity to those requirements.



# Complete Product Line

Call SCV Valve today @ (281) 482-4728 for all your valve needs or visit us on the web @ [www.scvvalve.com](http://www.scvvalve.com).

## THRU CONDUIT GATES - SLAB & EXPANDING

**Design: API 6D**  
 Sizes: 2" - 42"  
 Class: 150 - 1500  
 Standard stock.

**Design: API 6A**  
 Sizes: 9", 11" & 13-5/8"  
 Pressure: 2000, 3000, 5000  
 Limited inventory availability.  
 All sizes and pressure classes made to order.

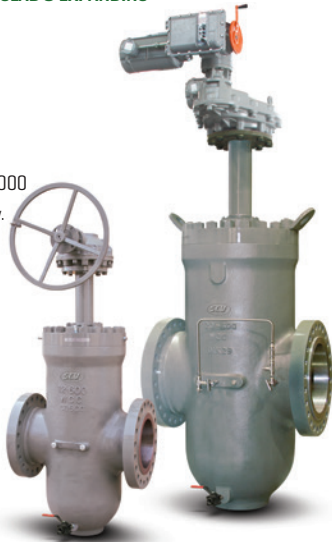

## PISTON CHECKS

**Design: API 6D**  
 Sizes: 2" - 24"  
 Class: 150 - 2500  
 Standard stock.



## GLOBES

**Design: API 623**  
 Sizes: 2" - 24"  
 Class: 150 - 2500

Limited inventory availability.  
 All sizes and pressure classes made to order.



## 3-PIECE TRUNNION BALLS

**Design: API 6D**  
 Sizes: 2" - 42"  
 Class: 150 - 2500  
 Standard stock.

Bore Coating: Scotchkote™ 134

**Design: API 6A**  
 Sizes: 2-1/16" - 7-1/6"  
 Pressure: 2000, 3000, 5000  
 Limited inventory availability.  
 All sizes and pressure classes made to order.



## FULL PORT SWING CHECKS

**Design: API 6D**  
 Sizes: 2" - 36"  
 Class: 150 - 2500  
 Standard stock.



Exterior Coating: Epoxy

## WEDGE GATES

**Design: API 600**  
 Sizes: 2" - 48"  
 Class: 150 - 2500

Limited inventory availability. All sizes and pressure classes made to order.



## FLOATING BALL VALVES

**Design: B16.34**  
 Sizes: 1/2" - 12"  
 Class: 150 - 1500  
 Standard stock.



## PRESSURE BALANCED LUBRICATED PLUGS

**Design: API 6D**  
 Sizes: 2" - 36"  
 Class: 150 - 2500  
 Standard stock.

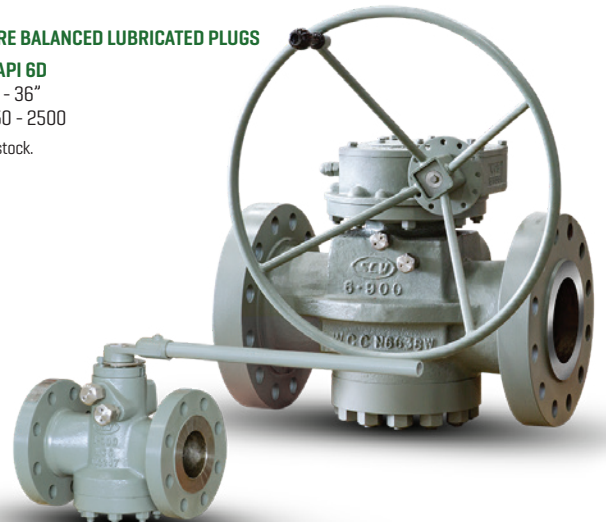



# Certifications & Registrations

## American Petroleum Institute (API)

### API 6A Certification



Note: Extension letter available on our website.

### API 6D Certification



Note: Extension letter available on our website.

### ISO 9001:2015 Certificate



### CE PED Certificate



### Canadian Registration Number

- Alberta  
- OC07063.2
- New Brunswick  
- OC07063.27
- Northwest Territory  
- OC07063.25
- Nunavut  
- OC07063.2N
- Ontario  
- OC07063.25
- Yukon  
- OC07063.2
- British Columbia  
- OC07063.21
- New Foundland & Labrador  
- OC07063.20
- Novascotia  
- OC07063.27
- Manitoba  
- OC07063.24
- Prince Edward Island  
- OC07063.29

# Valve ID Tag & Valve Markings Identification

## Valve ID Tag

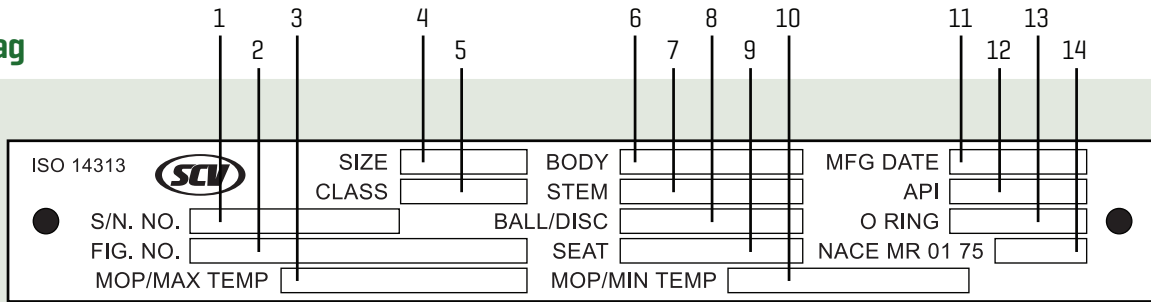

No.	Figure Number Code	Description
1	Serial Number	Identifies certified manufacturers serial number
2	Figure Number	Identifies the detailed valve configuration (valve type, bore size, pressure class, materials, etc.)
3	MOP/Max. Temp.	Identifies the maximum operating pressure in PSI and maximum operating temperature in Fahrenheit
4	Size	Identifies bore size
5	Pressure Class	Identifies pressure classifications per API requirements
6	Body Material	Identifies body metal material composition (A105, WCB, F51, CF8M, etc.)
7	Stem Material	Identifies stem material composition (A105, 410SS, 17-4pH, etc.)
8	Ball/Disc Material	Identifies ball/disc material composition (A105, 316SS, ENP, etc.)
9	Seat Material	Identifies seat material composition (PEEK, Teflon, Nylon, etc.)
10	MOP/Min. Temp.	Identifies the maximum operating pressure in PSI and minimum operating temperature in Fahrenheit
11	Manufacturing Date	Identifies the date the valve manufacturing completion date
12	API Conformance	Identifies API conformance (600, 6D, 6A, etc.)
13	O Ring	Identifies the O Ring material composition (Viton, Viton GLT, etc.)
14	NACE MR 01 75	Identifies corrosion resistance

## Valve Markings

No.	Valve ID Components
1	Tag
2	Brand
3	Size
4	Pressure Class
5	Body Material
6	Heat Number

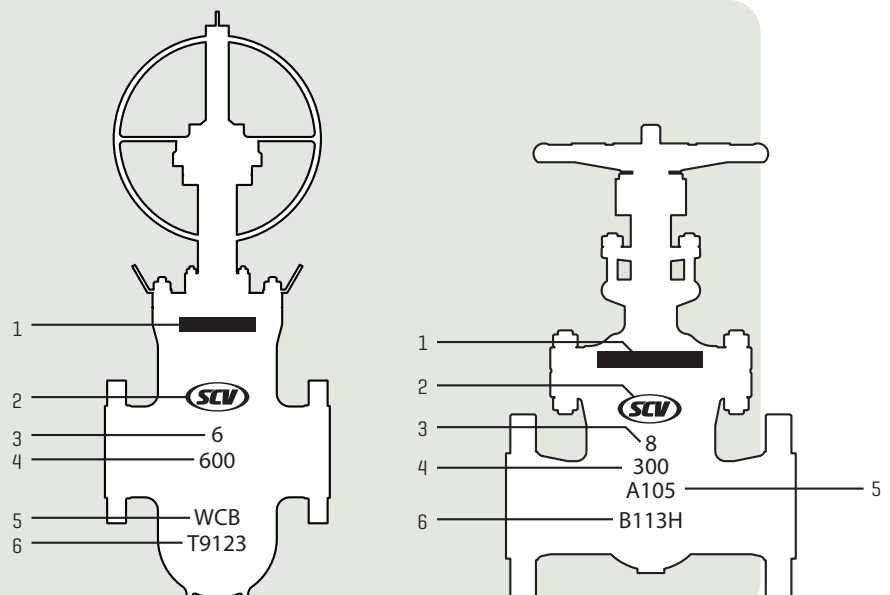



9

10

11

12

13

14

15

Bore Type	Seal Material	Seat Material	Seat Insert/Overlay Material	Stem Material	Packing Material	Service
F = Full Port	A = Aflas	/ = N/A	B = Nickel Boron	/ = N/A	/ = N/A	A = Stem Extension
R = Reduced Port	B = Buna	08 = A216 WCB	D = Devlon	A = A350 LF2 + ENP	B = Braided Graphoil	C = Cryogenic
C = Conventional	E = EPDM	09 = A351 CF8M	F = PTFE	B = A105 + ENP	G = Graphite	D = *DPE x DPE
T = Regular Pattern	F = Fluorosilicone	11 = CR13 HF	G = RTFE - Glass filled	C = A182 F6a Class 2	T = Teflon	E = External Coating
U = Short Pattern	G = Graphite	13 = A105 + ENP	H = Hard Face (Stellite 6)	D = 17-4 PH	V = Viton Duck	F = Dampener
V = Venturi Pattern	H = HNBR	14 = A105 + HF	K = PCTFE	F = A182 F316		G = Geothermal
	K = Kalrez	15 = A350 LF2 + ENP	N = Nylon	G = A182 F51 Duplex		H = High Temperature
	L = Lip Seal	16 = A350 LF2 + HF	P = Peek	H = A182 F56 Duplex		I = Internal Coating
	N = Neoprene	17 = 17-4 PH	R = RTFE - Carbon Filled	I = Inconel 625		J = **SPE x DPE
	P = Polyurethane	30 = A29 4130	T = Tungsten Carbide	J = 17-4 + QPQ		L = Lock Open Device
	R = NBR	32 = A182 316L + HF	V = Viton			P = Pipe Pups
	S = Silicone	35 = A182 316/HF	3 = 316			S = Standard Service
	T = Teflon	36 = A182 316	W = UHMWE			X = Special
	U = Floursint	41 = A182 F6a Class 2				
	V = Viton	42 = A182 F6a Class 2 + HF				
	3 = 304 Ring	51 = F51 Duplex				
	4 = 304 / Graphite	52 = A182 F51 Duplex + HF				
	5 = 316 Ring	54 = A182 F51 Duplex + CoCr-A				
	6 = 316 / Graphite	55 = F55 Duplex				
	7 = Soft Iron Ring	91 = A105/HF				

**Sample Figure Numbers & Descriptions**

	Figure No. Chart Column																
	1	2	3	4	5	6	7	8	9	10	11	12	13	14	15		
	Pressure Classes	Type	Size	Class	Body Conf.	Body	Obturator	End	Oper	Bore Type	Seal	Seat/base	Seat/Insert	Stem	Packing	Service	
<b>TRUNNION BALL</b>	150, 300, 600	BAL	12	06	B	12	15	R	G	F	H	15	D	A	/	S	
	12" 600 Trunnion Ball Valve, Bolted A350 LF2 Body, LF2 + ENP Obturator, RF Ends, Gear Operated, Full Bore, HNBR AED Seals, A350 LF2 + ENP Seat Base Material, Devlon Seat Inserts, A350 LF2 + ENP Stem, Standard Service, API 6D Design and Test, NACE MR-01-75 Compliant																
<b>FLOATING BALL</b>	900, 1500, 2500	BAL	12	15	B	12	41	J	G	F	H	41	D	C	/	S	
	12" 1500 Floating Ball Valve, Bolted Configuration, A350 LF2 Body, A182 F6a Class 2 Obturator, RTJ Ends, Gear Operated, Full Bore, HNBR AED Seals, A182 F6a Class 2 Seat Base Material, Devlon Seat Inserts, A182 F6a Class 2 Stem, Standard Service, API 6D Design and Test, NACE MR-01-75 Compliant																
<b>DUAL PLATE WAFER CHECK</b>	ALL	FBV	12	01	B	10	36	R	L	F	3	36	R	F	/	S	
	12" 150 Floating Ball Valve, Bolted Configuration, A216 WCB Body, A182 F316 Obturator, RF Ends, Lever Operated, Full Bore, A182 F316 Seat Base Material, Devlon Seat Inserts, A182 F316 Stem, Standard Service, API 608 Design, API 598 Test, NACE MR-01-75 Compliant																
<b>SLAB GATE</b>	ALL	DCK	12	06	W	10	09	R	/	C	/	08	H	/	/	S	
	12" 600 Dual Plate Check Valve, Wafer Configuration, A216 WCB Body, A351 CF8M Obturator, RF Ends, Conventional Bore, A216 WCB Seat Base Material, Hardface Seat Overlay, Standard Service, API 594 Design, API 598 Test, NACE MR-01-75 Compliant																
<b>EXPANDING GATE</b>	ALL	TCG	12	06	B	08	13	R	B	F	V	13	R	D	V	S	
	12" 600 Thru Conduit Slab Gate Valve, Bolted A216 WCC Body, A105 + ENP Obturator, RF Ends, Bare Stem, Full Bore, Viton AED Seals, A105 + ENP Seat Base Material, RTFE Seat Inserts, 17-4 PH Stem, Viton Duck Packing, Standard Service, API 6D Design and Test, NACE MR-01-75 Compliant																
<b>FULL PORT SWING CHECK</b>	ALL	EPG	12	06	B	08	06	R	B	F	V	13	R	D	V	S	
	12" 600 Thru Conduit Expanding Gate Valve, Bolted A216 WCC Body, A216 WCC + ENP Obturator, RF Ends, Bare Stem, Full Bore, Viton AED Seals, A105 + ENP Seat Base Material, RTFE Seat Inserts, 17-4 PH Stem, Viton Duck Packing, Standard Service, API 6D Design and Test, NACE MR-01-75 Compliant																
<b>PISTON CHECK</b>	ALL	FCK	12	06	B	08	16	R	/	F	V	11	V	/	/	S	
	150, 300, 600, 900	PCK	12	06	B	08	61	R	/	C	V	14	H	/	/	S	
	1500, 2500	PCK	12	15	B	08	61	R	/	C	V	41	H	/	/	S	
12" 600 Full Port Swing Check Valve, Bolted A216 WCC Body, A216 WCC + 316 Obturator, RF Ends, Full Bore, Viton AED Seals, CR13 HF Seat Base Material, Viton Seat Inserts, Standard Service, API 6D Design and Test, NACE MR-01-75 Compliant																	
<b>LUBRICATED PLUG</b>	ALL	GAT	12	06	B	10	84	R	L	C	V	/	/	/	G	S	
	12" 600 Lubricated Plug Valve, Bolted A216 WCC Body, A743 CA15 Obturator, RF Ends, Lever Operated, Conventional Bore, Viton AED Seals, Standard Service, API 6D Design and Test, NACE MR-01-75 Compliant																
<b>WEDGE GATE</b>	ALL	GAT	12	06	B	10	7	R	H	C	4	14	H	C	G	S	
	12" 600 Wedge Gate Valve, Bolted A216 WCC Body, A216 WCC + Hardface Obturator, RF Ends, Handwheel Operated, Conventional Bore, 304 + Graphite Gasket, A105 Seat Base Material, Hardface Seat Overlay, A182 F6a Class 2 Stem, Graphite Packing, Standard Service, API 600 Design, API 598 Test, NACE MR-01-75 Compliant																
<b>GLOBE</b>	ALL	GLB	12	06	B	10	60	R	H	C	4	14	H	C	G	S	
	12" 600 Globe Valve, Bolted A216 WCC Body, A105 + Hardface Obturator, RF Ends, Handwheel Operated, Conventional Bore, 304 + Graphite Gasket, A105 Seat Base Material, Hardface Seat Overlay, A182 F6a Class 2 Stem, Graphite Packing, Standard Service, API 623 Design, API 598 Test, NACE MR-01-75 Compliant																

**Note:** Subject to change without notice.  
**Control #:** MSF 3.5-16 rev 17





## Geothermal Thru Conduit Slab & Expanding Gate Valves

Class: 150 - 900/Sizes: 4" - 24"



Design and Manufacturing Standards	
Basic Design	API 6D
Face-to-Face Dimension	ANSI B16.10
Flange End Dimension	ANSI/ASME B16.5 (4" to 24")
Inspection & Testing	API 6D
Fire Safe Design	API 6FA





For more information call us @ (281) 482-4728 or visit our website @ [www.scvvalve.com](http://www.scvvalve.com)

## SCV Thru Conduit Slab & Expanding Gate Valves

- Basic Design: API 6D
- Face-to-Face Dimension: ANSI B16.10
- Flange End Dimension: ANSI/ASME B16.5 (4" to 24")
- Inspection & Testing: API 6D
- Fire Safe Design: API 6FA

## SCV Thru Conduit Slab Gate (Bi-Directional)

- Pressure assisted seats for high pressure sealing
- Spring loaded seat for low pressure sealing
- Double block and bleed capabilities
- Internal pressure relieving through self-relieving seats
- Seat injection fittings
- Injectable stem packing capability (with Chevron style packing)
- Full port thru conduit for passage of pigs
- Open yoke adjustable packing gland available upon request

## SCV Thru Conduit Expanding Gate (Bi-Directional) with Preferred Pressure Side

- Expanding mechanical gate forms positive tight sealing
- Seals at low and high pressure
- Double block and bleed capabilities
- Seat injection fittings
- Injectable stem packing capability (with Chevron style packing)
- Optional by-pass system for thermal cavity relief venting
- Full port thru conduit for passage of pigs
- Open yoke adjustable packing gland available upon request

## Trim Configuration Options

- Solid Inconel stem
- Solid 316 SS stem
- Solid 17-4 PH stem
- Solid Inconel gate
- Inconel lined bore & seal area
- Solid stainless steel gate w/hardface overlay

## Drain Configuration Options

- Threaded Nipple & Valve Assembly
- Welded Nipple & Flange Assembly

**Note:** Not recommended for throttling applications.

**Note:** SCV reserves the right to change any technical design and dimensional data without prior notice. Please contact SCV to confirm all Dimensions and Data offered in this catalog.

# Thru Conduit Slab Gate Valve (Bi-Directional)

## [ Expanded View & Bill of Materials ]

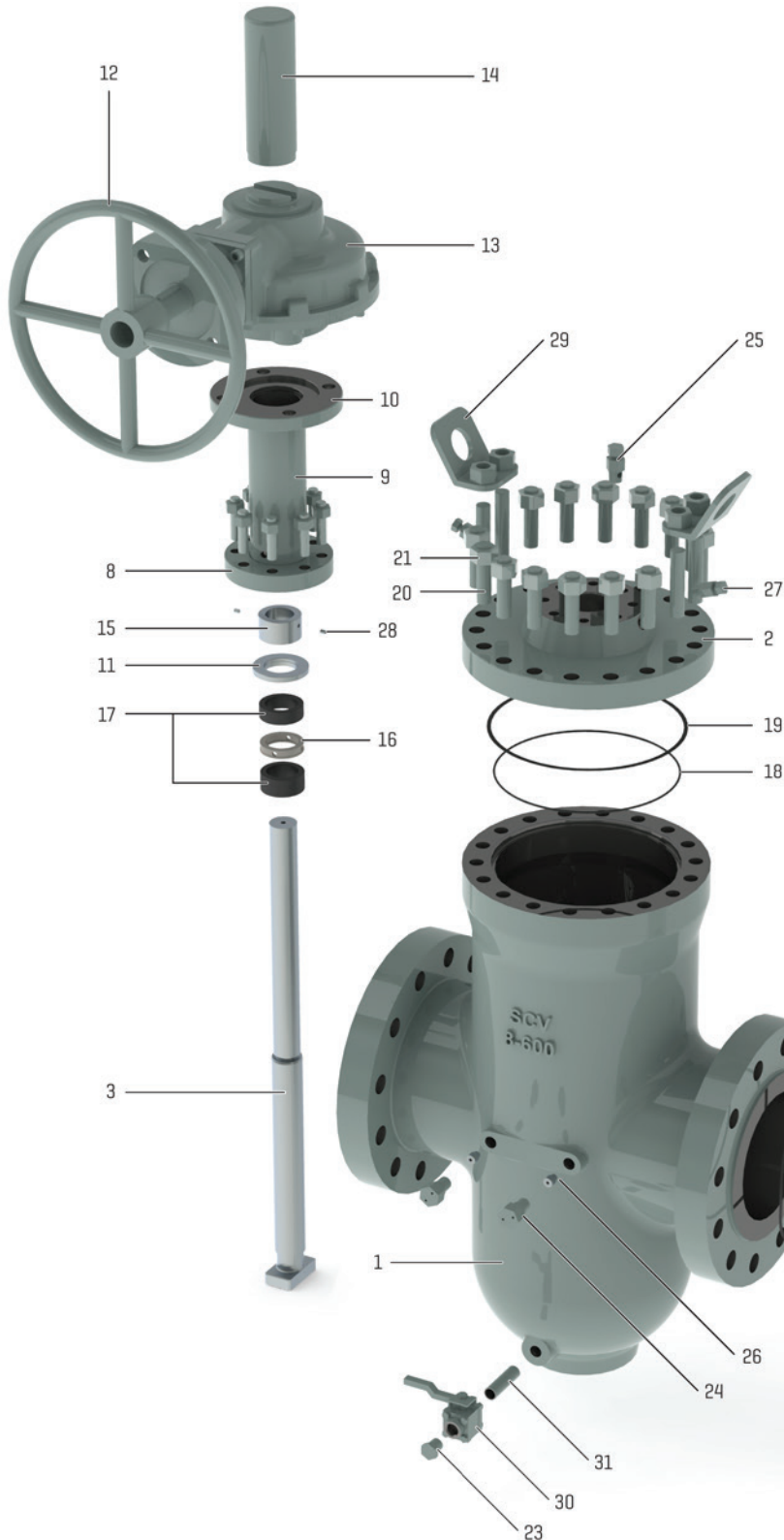

No.	Part	Material
1	Body	*ASTM A216 WCC
2	Bonnet	*ASTM A105
3	Stem	ASTM A564 T Type 630, 17-4 or Inconel 625
4	Seat	410 or 316L Stellite Hardface
5	Seat Face	Stellite Hardface
6	Seat O-Rings	Viton AED or L'Garde EPDM
7	Gate	ASTM A105 or 316L + Stellite Hardface
8	Yoke Base	ASTM A105
9	Yoke Tube	ASTM A106 Gr. B Pipe
10	Yoke Top	ASTM A105
11	Lantern Ring	PEEK
12	Handwheel	Carbon Steel
13	Gear	Carbon Steel
14	Stem Protector	Clear Plastic
15	Internal Stop Nut	ASTM A105
16	Gland	ASTM A105 or Inconel 625
17	Packing	Viton/Duck or 40% Glass Filled Teflon
18	Bonnet O-Ring	Viton AED or L'Garde EPDM
19	Gasket	Stainless Steel/Graphite - GHE
20	Stud	ASTM A193 B7/2H
21	Heavy Hex Nut	ASTM A194 2H
22	Wavespring / O-Ring	17-7 Stainless Steel / Viton AED or L'Garde EPDM
23	NPT Plug	316 Stainless Steel
24	Grease Fitting, GBH	316 Stainless Steel
25	Vent Fitting	316 Stainless Steel
26	Ball Check	316 Stainless Steel
27	Packing Injection Fitting	316 Stainless Steel
28	Set Screw	B7
29	Lift Plate	A36
30	Ball Valve	Carbon Steel
31	Pipe Nipple	ASTM A106

\* = Body/Bonnet available with Inconel overlay in seal areas and bore.

# Thru Conduit Expanding Gate Valve (Bi-Directional) with Preferred Pressure Side

[ Expanded View & Bill of Materials ]

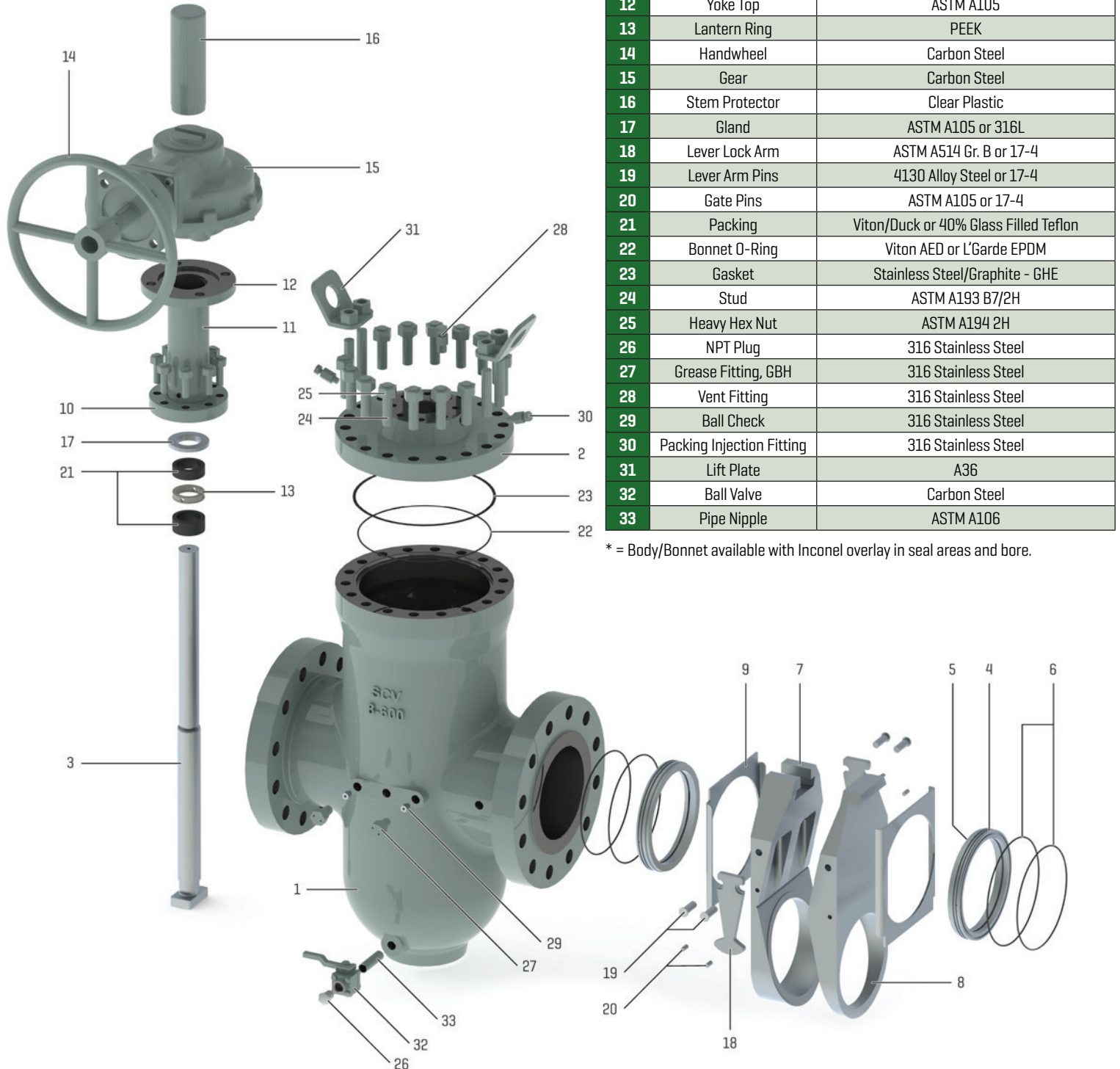

No.	Part	Material
1	Body	*ASTM A216 WCC
2	Bonnet	*ASTM A105
3	Stem	ASTM A564 TType 630, 17-4 or Inconel 625
4	Seat	410 or 316L Stellite Hardface
5	Seat Face	Stellite Hardface
6	Seat O-Rings	Viton AED
7	Gate	ASTM A216 WCC or ASTM A351 CF3M + Stellite Hardface
8	Segment	ASTM A216 WCC + ENP or ASTM A351 CF3M + Stellite Hardface
9	Skirt	ASTM A573 Gr. 50 or 316L
10	Yoke Base	ASTM A105
11	Yoke Tube	ASTM A106 Gr. B Pipe
12	Yoke Top	ASTM A105
13	Lantern Ring	PEEK
14	Handwheel	Carbon Steel
15	Gear	Carbon Steel
16	Stem Protector	Clear Plastic
17	Gland	ASTM A105 or 316L
18	Lever Lock Arm	ASTM A514 Gr. B or 17-4
19	Lever Arm Pins	4130 Alloy Steel or 17-4
20	Gate Pins	ASTM A105 or 17-4
21	Packing	Viton/Duck or 40% Glass Filled Teflon
22	Bonnet O-Ring	Viton AED or L'Garde EPDM
23	Gasket	Stainless Steel/Graphite - GHE
24	Stud	ASTM A193 B7/2H
25	Heavy Hex Nut	ASTM A194 2H
26	NPT Plug	316 Stainless Steel
27	Grease Fitting, GBH	316 Stainless Steel
28	Vent Fitting	316 Stainless Steel
29	Ball Check	316 Stainless Steel
30	Packing Injection Fitting	316 Stainless Steel
31	Lift Plate	A36
32	Ball Valve	Carbon Steel
33	Pipe Nipple	ASTM A106

\* = Body/Bonnet available with Inconel overlay in seal areas and bore.



# Slab Gate Advanced Mechanical Details

Through its simple design and efficient performance, the slab gate's two spring loaded floating seats are pressure energized. This allows for complete sealing, both upstream and downstream.

## [ Features Overview ]

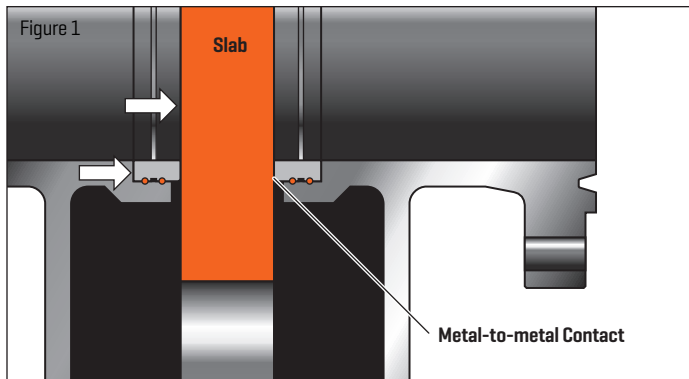

### Seats - Metal

The spring loaded double O-ring design seats maintain a perfect seal with the gate in both low and high pressure applications. **(Figure 1)**

### Double Block

When the valve is in the closed position and also has equal or no pressure, both spring loaded seats can shut off line pressure independently of upstream and downstream pressure. This creates a double block scenario. **(Figure 2)**

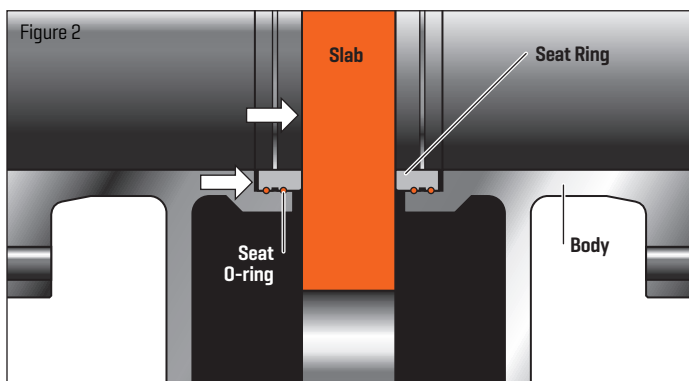

When line pressure is applied, the pressure forces the slab gate to float against the downstream seat and form a tight seal. At the same time, the upstream line pressure forces the upstream seat on the slab gate to form an upstream seal. **(Figure 3)**

### Self Relieving Cavity

The double block and bleed slab gate design, in the closed position, may experience an increase in cavity pressure due to thermal expansion. When the cavity pressure exceeds the line pressure, the seat is forced away from the gate surface allowing the excess cavity pressure to be vented into the line. This allows for a pressure balance between the body cavity and the line. The valve body pressure will relieve to the lower differential side. **(Figure 4)**

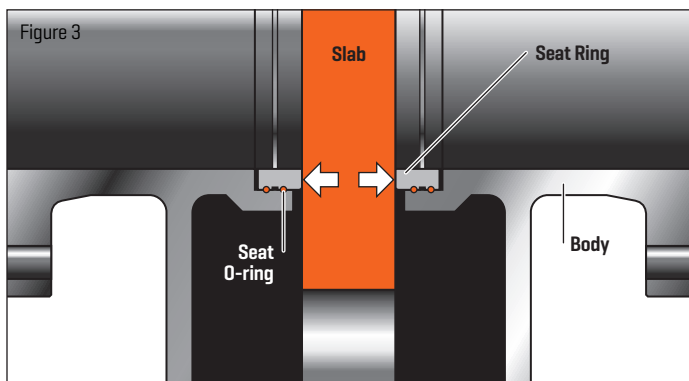

### Secondary Sealant and Packing Injection System

All valves will have secondary sealant injection fittings for the stem and seats. **(Figure 5)**

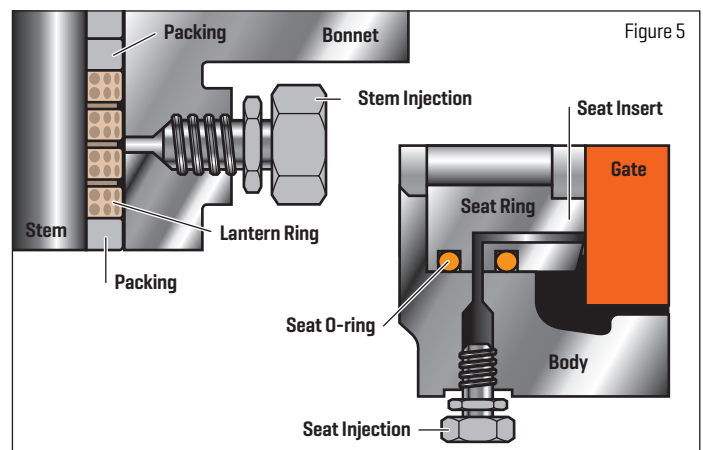
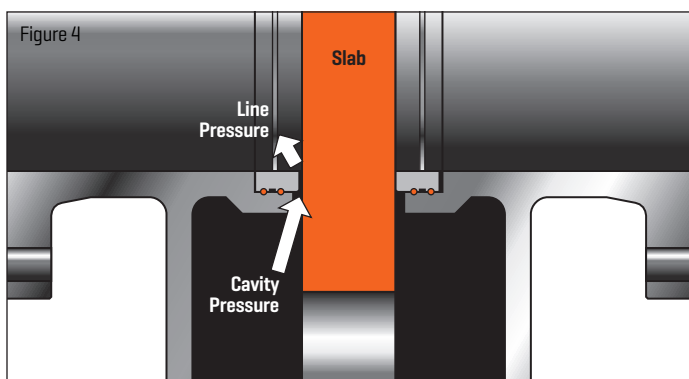

# Expanding Gate Advanced Mechanical Details

The SCV Expanding Gate valve design provides a mechanical seal between the seats and the gate in both high and low pressure applications. The expanding gate valve does not require line pressure to seal and is recommended when a tight mechanical seal is required.

## [ Features Overview ]

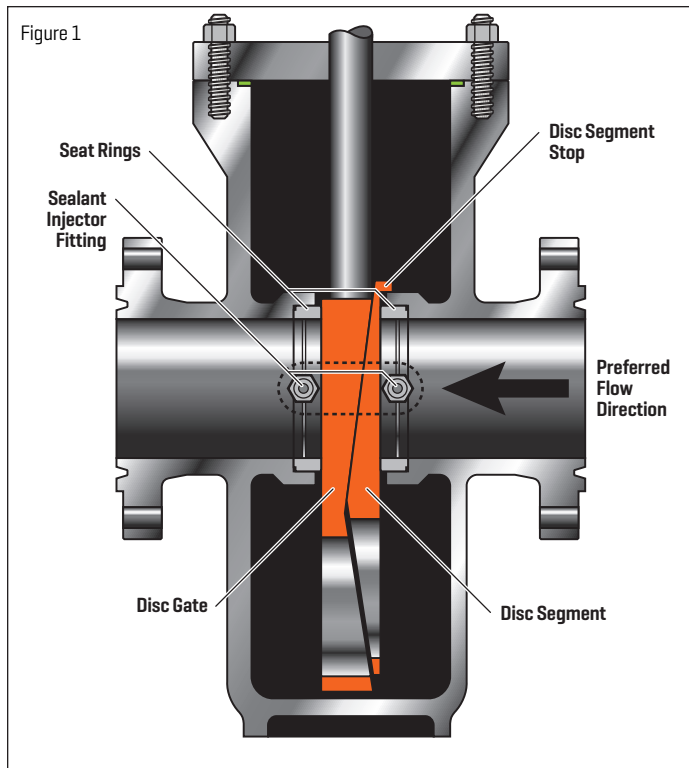

### Full Expanded Closed

In the full expanded closed position, the segment stop has engaged with the lower body stop and the gate is wedged downward, expanding the gate and segment to form a tight seal against the upstream and downstream seats. Body cavity venting will assist to provide tight shut off. **(Figure 1)**

### Mid Position

When operating towards the open position, the gate travels across the wedge angle of the segment. This retracts the assembly so that it will slide freely between the seat faces. **(Figure 2)**

### Full Expanded Open

In the full expanded open position, the segment stop has engaged the upper body stop and the gate is wedged upward. This expands the segment and the gate into the seats, isolating the flow from the cavity. **(Figure 3)**

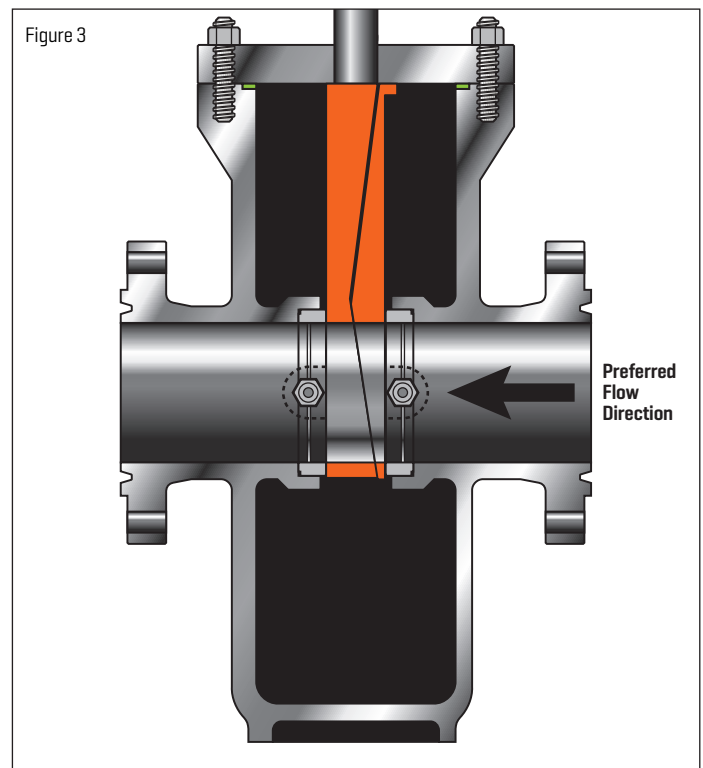
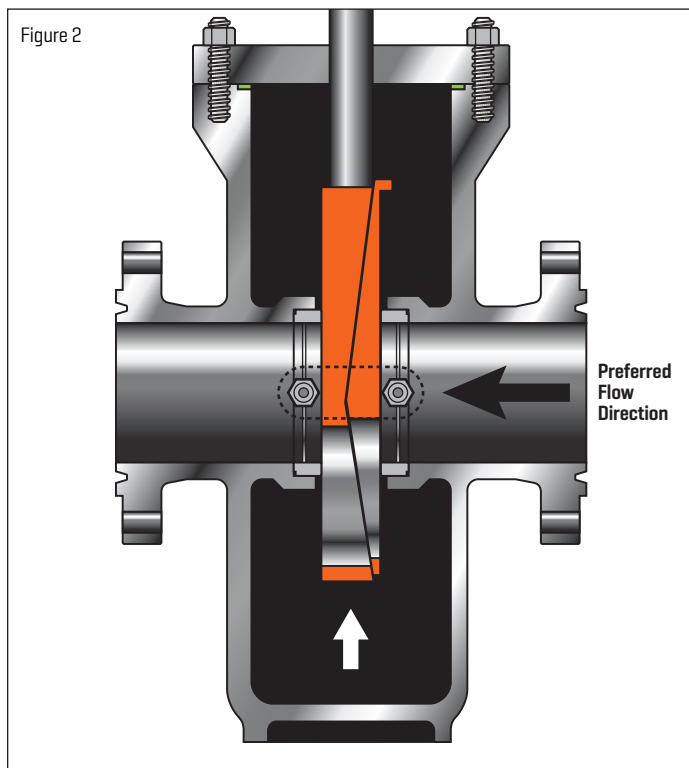

# Geothermal Slab & Expanding Gate Advanced Mechanical Details

Through its simple design and efficient performance, the slab gate's two spring loaded floating seats are pressure energized. This allows for complete sealing, both upstream and downstream.

[ [Features Overview](#) ]

## Trim Overlay Options



### STELLITE OVERLAY

- Gate Seating Surface - Raised .125 Figure 8 Overlay
- Seat Sealing Surface



### INCONEL 625 OVERLAY OPTIONS

- Body Bore
- Seat Pockets
- Bonnet Connection
- Packing Box
- Flange Connection
- Yoke Tube Bottom

### DRAIN CONFIGURATION OPTIONS

- Threaded Nipple & Valve Assembly
- Welded Nipple & Flange Assembly

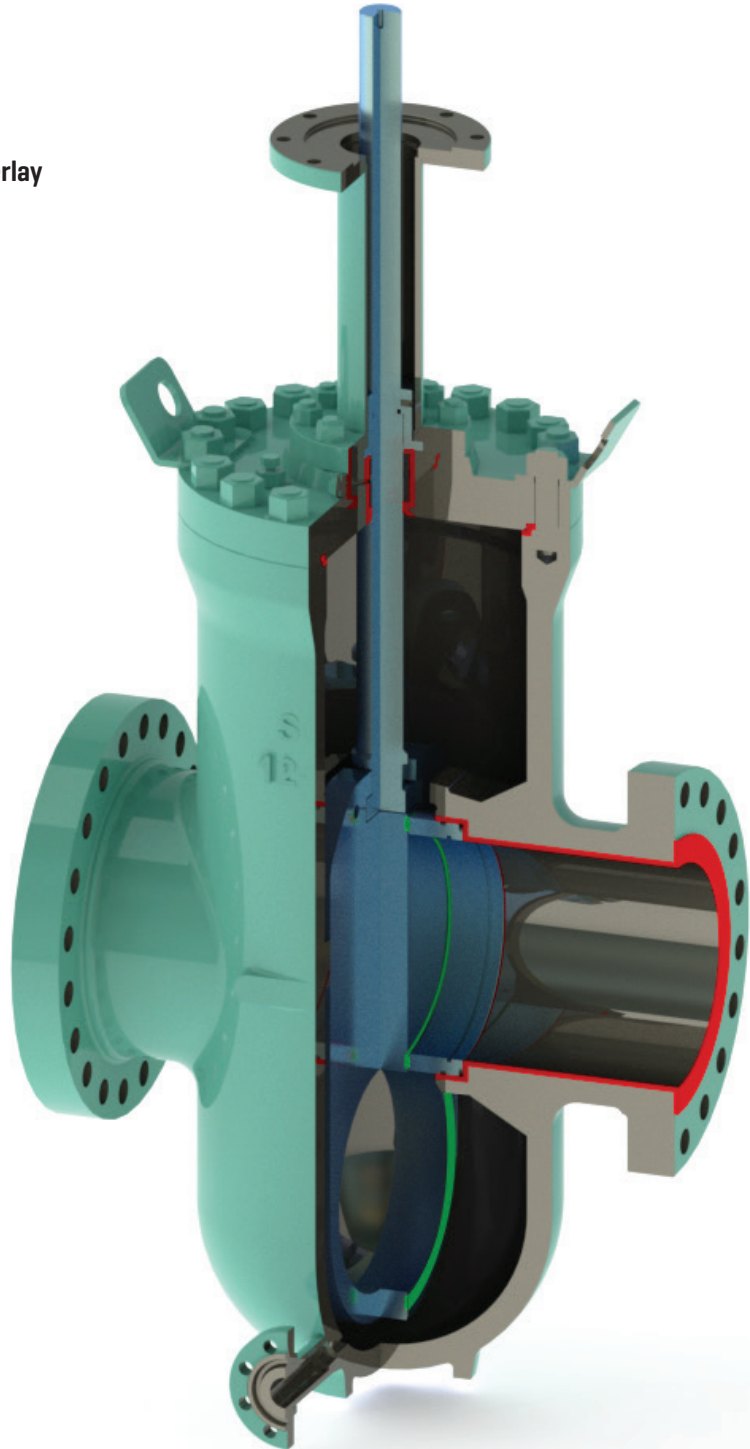



# Geothermal Slab & Expanding Gate Manufacturing Photos 12" 600 Class



Body/Bonnet Connection - Inconel 625 Overlay



2" Flanged Body Drain Connection



12" 600 Class Geothermal Body



Bore & Flange Sealing Face - Inconel 625 Overlay

**Slab Gate Valve Dimensions**  
**Size: 4" - 24"**  
**Class: 150 & 300**

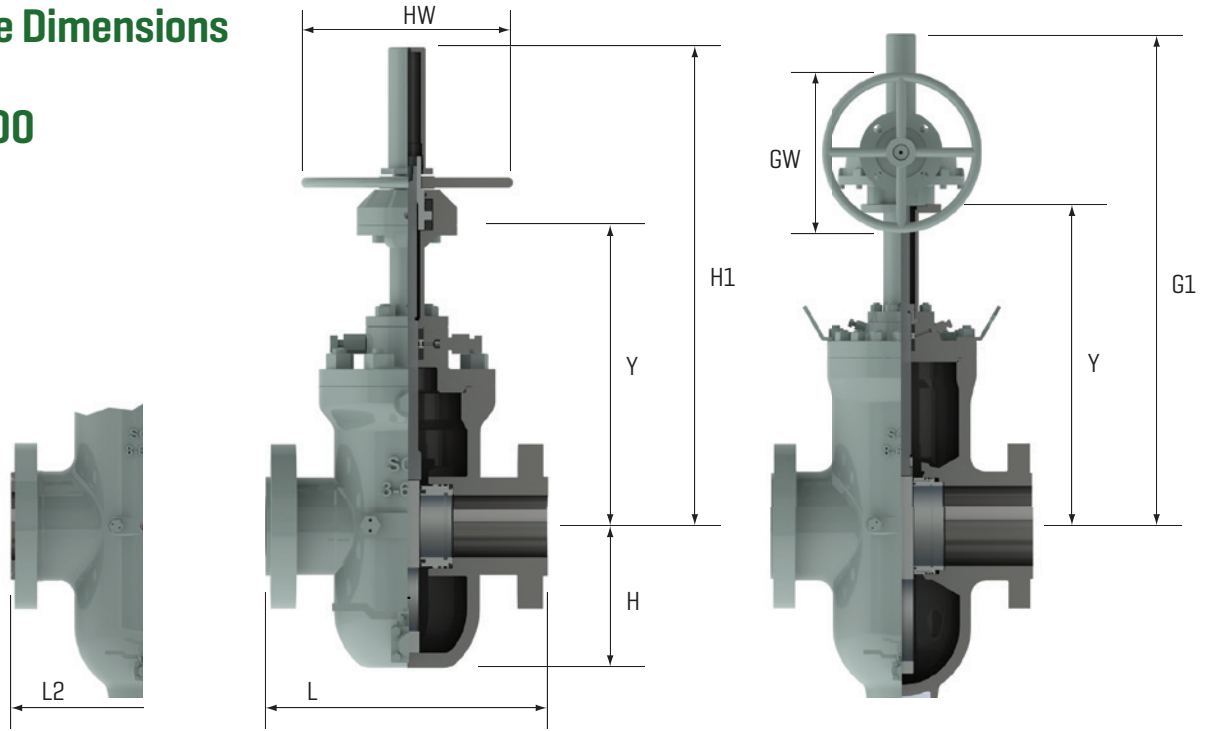

	SIZE		BORE	END-TO-END	CENTER-TO-BOTTOM	CENTER-TO-TOP OF YOKE	HANDWHEEL OPERATED		GEAR OPERATED		WEIGHTS
	IN	MM	F	RTJ - L2	H	Y	H1	HW	G1	GW	LBS/KG
<b>CLASS 150</b>	IN	4	4.06	9.00	9.0	16.9	26.2	10.0	26.2	10.0	150
	MM	100	103	229	229	429	665	254	665	254	68
	IN	6	6.06	10.50	11.5	21.6	33.7	12.0	33.7	12.0	202
	MM	150	154	267	292	549	856	305	856	305	92
	IN	8	8.06	11.50	15.3	27.7	42.1	18.0	42.1	18.0	373
	MM	200	205	292	389	704	1069	457	1069	457	169
	IN	10	10.06	13.00	18.1	33.1	50.7	18.0	50.7	18.0	536
	MM	250	256	330	460	841	1288	457	1288	457	243
	IN	12	12.06	14.00	22.0	38.6	58.4	18.0	58.4	18.0	868
	MM	300	306	356	559	980	1483	457	1483	457	394
	IN	14	13.25	15.00	23.8	41.4	62.4	18.0	62.4	18.0	1125
	MM	350	337	381	605	1052	1585	457	1585	457	510
	IN	16	15.25	16.00	26.5	46.7	70.5	18.0	70.5	18.0	1516
	MM	400	387	406	673	1186	1791	457	1791	457	688
	IN	18	17.25	17.00	29.5	51.3	78.2	18.0	78.2	18.0	1893
	MM	450	438	432	749	1303	1986	457	1986	457	859
	IN	20	19.25	18.00	33.2	57.2	85.1	24.0	85.1	24.0	2561
	MM	500	489	457	843	1453	2162	610	2162	610	1162
	IN	24	23.25	20.00	39.7	68.6	101.2	24.0	101.2	24.0	4245
	MM	600	591	508	1008	1742	2570	610	2570	610	1926
	IN	20	19.19	47.25	36.8	65.7	98.3	30.0	98.3	30.0	8325
	MM	500	487	1200	935	1669	2497	610	2497	610	3776
	IN	22	21.25	/	40.8	72.4	107.3	24.0	107.3	24.0	10292
	MM	550	540	/	1036	1839	2725	610	2725	610	4668
IN	24	23.25	55.38	44.5	78.3	115.3	24.0	115.3	24.0	12718	
MM	600	591	508	1008	1742	2570	610	2570	610	1926	
<b>CLASS 300</b>	IN	4	4.06	12.00	9.0	16.9	26.2	10.0	26.2	10.0	181
	MM	100	103	305	229	429	665	254	665	254	82
	IN	6	6.06	15.88	11.5	21.6	33.7	12.0	33.7	12.0	335
	MM	150	154	403	292	549	856	305	856	305	152
	IN	8	8.06	16.50	15.3	27.7	42.1	18.0	42.1	18.0	609
	MM	200	205	419	389	704	1069	457	1069	457	276
	IN	10	10.06	18.00	18.1	33.1	50.7	18.0	50.7	18.0	1000
	MM	250	256	457	460	841	1288	457	1288	457	454
	IN	12	12.06	19.75	22.0	38.6	58.4	18.0	58.4	18.0	1402
	MM	300	306	502	559	980	1483	457	1483	457	636
	IN	16	15.25	33.00	26.5	46.7	70.5	18.0	70.5	18.0	2764
	MM	400	387	838	673	1186	1791	457	1791	457	1254
	IN	20	19.25	39.00	33.2	57.2	85.1	24.0	85.1	24.0	4429
	MM	500	489	991	843	1453	2162	610	2162	610	2009
	IN	22	21.25	43.00	38.5	66.4	98.5	24.0	98.5	24.0	6488
	MM	550	540	1092	978	1687	2502	610	2502	610	2943
	IN	24	23.25	45.00	39.7	68.6	101.2	24.0	101.2	24.0	7039
	MM	600	591	1143	1008	1742	2570	610	2570	610	3193

Note: SCV reserves the right to change any technical design and dimensional data without prior notice. Please contact SCV to confirm all Dimensions and Data offered in this catalog. Larger sizes can be engineered if needed.

# Expanding Gate Valve Dimensions

Size: 4" - 24"  
Class: 150 & 300

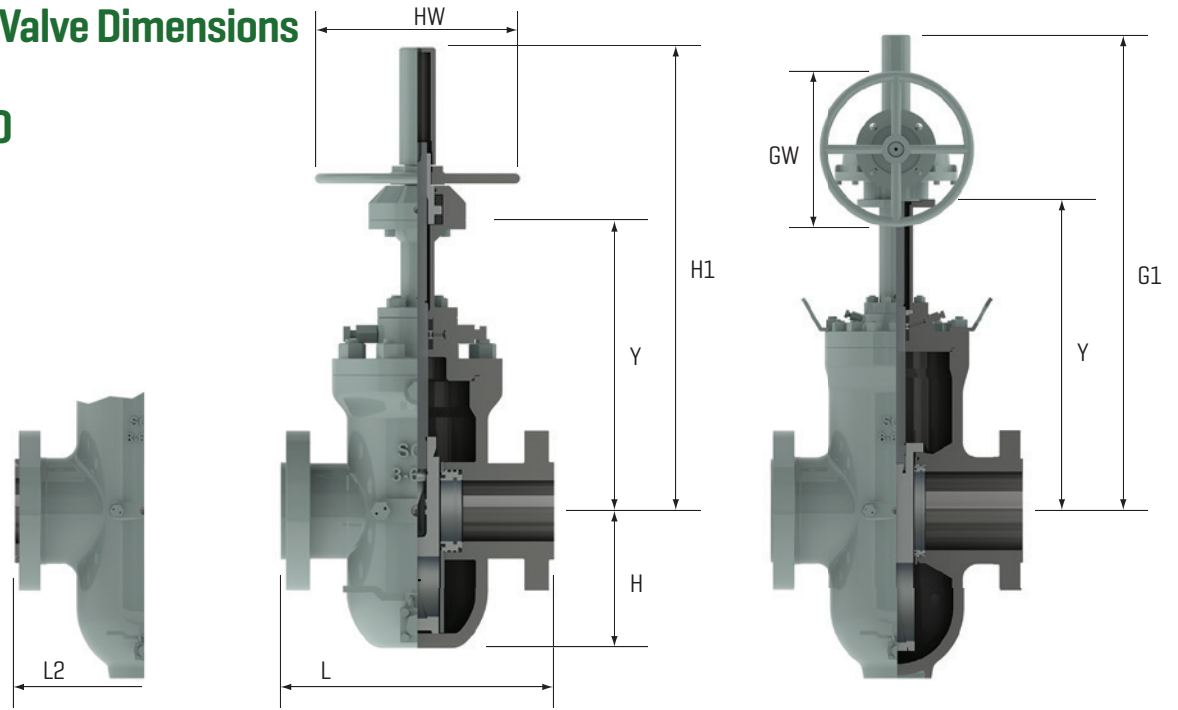

	SIZE		BORE	END-TO-END	CENTER-TO-BOTTOM	CENTER-TO-TOP OF YOKE	HANDWHEEL OPERATED		GEAR OPERATED		WEIGHTS	
	IN	MM	F	RF - L	H	Y	H1	HW	G1	GW	LBS/KG	
<b>CLASS 150</b>	IN	4	4.06	9.00	9.0	16.9	274	10.0	274	10.0	150	
	MM	100	103	229	229	429	696	254	696	254	68	
	IN	6	6.06	10.50	12.1	21.7	34.0	12.0	34.0	12.0	232	
	MM	150	154	267	307	551	864	305	864	305	105	
	IN	8	8.06	11.50	15.9	27.9	43.1	18.0	43.1	18.0	434	
	MM	200	205	292	404	709	1095	457	1095	457	197	
	IN	10	10.06	13.00	19.4	33.5	51.6	18.0	51.6	18.0	713	
	MM	250	256	330	493	851	1311	457	1311	457	323	
	IN	12	12.06	14.00	22.6	39.1	59.2	18.0	59.2	18.0	1053	
	MM	300	306	356	574	993	154	457	154	457	478	
	IN	16	15.25	16.00	28.0	47.9	72.0	18.0	72.0	18.0	1922	
	MM	400	387	406	711	1217	1829	457	1829	457	872	
	IN	18	/	/	/	/	/	/	/	/	/	/
	MM	450	/	/	/	/	/	/	/	/	/	/
	IN	20	19.25	18.00	34.5	58.0	86.1	24.0	86.1	24.0	3361	
	MM	500	489	457	876	1473	2187	610	2187	610	1525	
	IN	22	21.25	19.00	38.8	/	99.3	24.0	99.3	24.0	4495	
	MM	550	540	483	986	/	2522	610	2522	610	2039	
	IN	24	23.25	20.00	40.8	70.4	103.1	24.0	103.1	24.0	5172	
	MM	600	591	508	1036	1788	2619	610	2619	610	2346	
IN	20	19.19	47.25	36.8	65.7	98.3	30.0	98.3	30.0	8325		
MM	500	487	1200	935	1669	2497	610	2497	610	3776		
IN	22	21.25	/	40.8	72.4	107.3	24.0	107.3	24.0	10292		
MM	550	540	/	1036	1839	2725	610	2725	610	4668		
IN	24	23.25	55.38	44.5	78.3	115.3	24.0	115.3	24.0	12718		
MM	600	591	508	1008	1742	2570	610	2570	610	1926		
<b>CLASS 300</b>	IN	4	4.06	12.00	9.0	16.9	26.2	10.0	26.2	10.0	181	
	MM	100	103	305	229	429	665	254	665	254	82	
	IN	6	6.06	15.88	11.5	21.6	33.7	12.0	33.7	12.0	310	
	MM	150	154	403	292	549	856	305	856	305	141	
	IN	8	8.06	16.50	15.3	27.7	42.1	18.0	42.1	18.0	540	
	MM	200	205	419	389	704	1069	457	1069	457	245	
	IN	10	10.06	18.00	18.1	33.1	50.7	18.0	50.7	18.0	733	
	MM	250	256	457	460	841	1288	457	1288	457	332	
	IN	12	12.06	19.75	22.0	38.6	58.4	18.0	58.4	18.0	1300	
	MM	300	306	502	559	980	1483	457	1483	457	590	
	IN	14	13.25	30.00	23.8	41.4	62.4	18.0	62.4	18.0	1626	
	MM	350	337	762	605	1052	1585	457	1585	457	738	
	IN	16	15.25	33.00	26.5	46.7	70.5	18.0	70.5	18.0	2420	
	MM	400	387	838	673	1186	1791	457	1791	457	1098	
	IN	18	17.25	36.00	29.5	51.3	78.2	18.0	78.2	18.0	3197	
	MM	450	438	914	749	1303	1986	457	1986	457	1450	
	IN	20	19.25	39.00	33.2	57.2	85.1	24.0	85.1	24.0	4000	
	MM	500	489	991	843	1453	2162	610	2162	610	1814	
	IN	24	23.25	45.00	39.7	68.6	101.2	24.0	101.2	24.0	6391	
	MM	600	591	1143	1008	1742	2570	610	2570	610	2899	



**Slab Gate Valve Dimensions**  
**Size: 4" - 24"**  
**Class: 600 & 900**

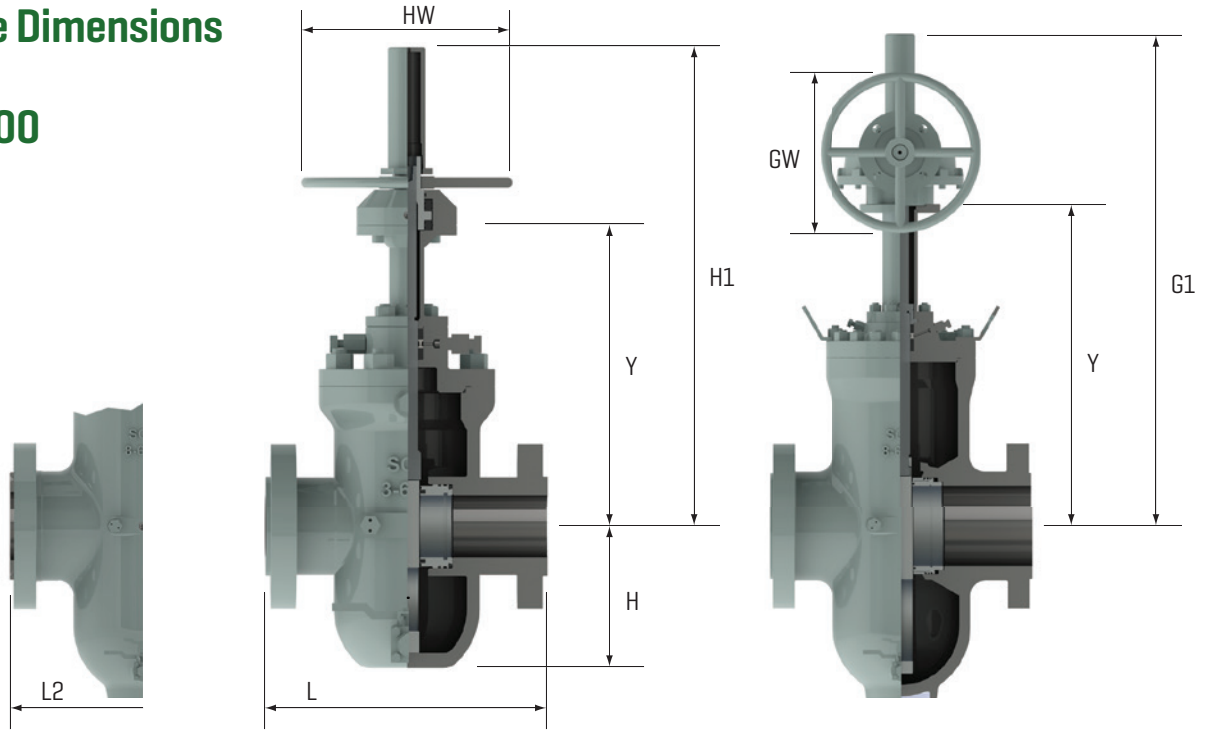

	SIZE		BORE	END-TO-END		CENTER-TO-BOTTOM	CENTER-TO-TOP OF YOKE	HANDWHEEL OPERATED	GEAR OPERATED		WEIGHTS	
	IN	MM	F	RF - L	RTJ - L2	H	Y	H1	HW	G1	GW	LBS/KG
<b>CLASS 600</b>	4	100	4.06	17.00	17.12	10.1	20.5	31.4	12.0	31.4	12.0	350
	6	150	6.06	22.00	22.12	12.8	25.8	39.3	18.0	39.3	18.0	603
	8	200	8.06	26.00	26.12	17.1	31.9	48.5	18.0	48.5	18.0	1069
	10	250	10.06	31.00	31.12	21.3	38.0	57.6	18.0	57.6	18.0	1846
	12	300	12.06	33.00	33.12	23.5	43.9	64.9	18.0	64.9	18.0	2442
	14	350	13.25	35.00	35.12	26.8	47.4	71.4	24.0	71.4	24.0	3237
	16	400	15.25	39.00	39.12	29.5	52.8	77.6	24.0	77.6	24.0	4204
	18	450	17.25	43.00	43.12	33.3	58.2	87.8	24.0	87.8	24.0	5880
	20	500	19.19	47.00	47.25	36.8	65.7	98.3	30.0	98.3	30.0	8325
	22	550	21.25	51.00	/	40.8	72.4	107.3	24.0	107.3	24.0	10292
	24	600	23.25	55.00	55.38	44.5	78.3	115.3	24.0	115.3	24.0	12718
	4	100	4.06	18.00	18.12	10.3	20.5	31.4	12.0	31.4	12.0	403
	6	150	6.06	24.00	24.12	13.1	25.8	39.2	18.0	39.2	18.0	800
	8	200	8.06	29.00	29.12	17.5	31.9	48.5	18.0	48.5	18.0	1346
	10	250	10.06	33.00	33.12	21.8	38.0	57.6	18.0	57.6	18.0	2380
	12	300	12.06	38.00	38.12	24.4	43.9	65.6	24.0	65.6	24.0	3258
	14	350	13.25	40.50	40.88	27.9	47.4	71.4	24.0	71.4	24.0	4208
	16	400	15.25	43.00	43.12	29.5	52.8	77.6	24.0	77.6	24.0	4204
	18	450	17.25	47.00	47.25	36.8	65.7	98.3	30.0	98.3	30.0	8325
	20	500	19.19	51.00	/	40.8	72.4	107.3	24.0	107.3	24.0	10292
22	550	21.25	55.00	55.38	44.5	78.3	115.3	24.0	115.3	24.0	12718	
24	600	23.25	59.00	59.38	48.2	84.2	123.3	24.0	123.3	24.0	15144	

# Expanding Gate Valve Dimensions

Size: 4" - 24"  
Class: 600 & 900

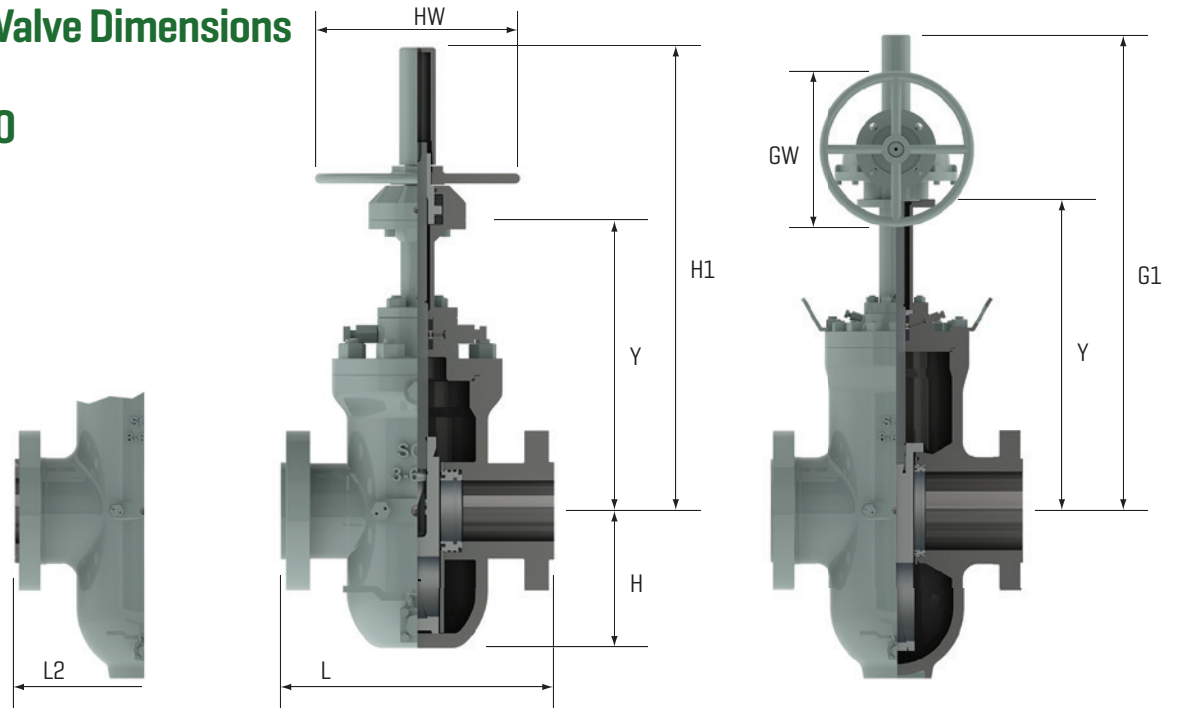

CLASS	SIZE		BORE	END-TO-END		CENTER-TO-BOTTOM	CENTER-TO-TOP OF YOKE	HANDWHEEL OPERATED		GEAR OPERATED		WEIGHTS LBS/KG
	IN	MM	F	RF - L	RTJ - L2	H	Y	H1	HW	G1	GW	
CLASS 600	IN	4	4.06	17.00	17.12	10.1	20.5	31.4	12.0	31.4	12.0	349
	MM	100	103	432	435	257	521	798	305	798	305	158
	IN	6	6.06	22.00	22.12	12.8	25.8	39.3	18.0	39.3	18.0	601
	MM	150	154	559	562	325	655	998	457	998	457	273
	IN	8	8.06	26.00	26.12	17.1	31.9	48.5	18.0	48.5	18.0	1075
	MM	200	205	660	663	434	810	1232	457	1232	457	488
	IN	10	10.06	31.00	31.12	21.3	38.0	57.6	18.0	57.6	18.0	1876
	MM	250	256	787	790	541	965	1463	457	1463	457	851
	IN	10.375	10.375	31.00	31.12	21.3	38.0	57.6	18.0	57.6	18.0	1876
	MM	263.5	263.5	787	790	541	965	1463	457	1463	457	851
	IN	12	12.06	33.00	33.12	23.5	43.9	64.9	18.0	64.9	18.0	2494
	MM	300	306	838	841	597	1115	1648	457	1648	457	1131
	IN	12.375	12.375	33.00	33.12	23.5	43.9	64.9	18.0	64.9	18.0	2494
	MM	314.3	314.3	838	841	597	1115	1648	457	1648	457	1131
	IN	14	13.25	35.00	35.12	26.8	47.4	71.4	24.0	71.4	24.0	3327
	MM	350	337	889	892	681	1204	1814	610	1814	610	1059
	IN	16	15.25	39.00	39.12	29.5	52.8	77.6	24.0	77.6	24.0	4367
	MM	400	387	991	994	749	1341	1971	610	1971	610	1981
	IN	18	17.25	43.00	43.12	33.1	58.2	87.8	24.0	87.8	24.0	6047
	MM	450	438	1092	1095	841	1478	2230	610	2230	610	2743
	IN	20	19.19	47.00	47.25	36.8	65.7	98.3	30.0	98.3	30.0	8610
MM	500	487	1194	1200	935	1669	2497	610	2497	610	3905	
IN	22	21.25	51.00	/	40.8	72.4	107.3	24.0	107.3	24.0	10720	
MM	550	540	1295	/	1036	1839	2725	610	2725	610	4863	
IN	24	23.25	55.00	55.38	44.5	78.3	115.3	24.0	115.3	24.0	13315	
MM	600	591	1397	1407	1130	1989	2929	610	2929	610	6040	
CLASS 900	IN	4	4.06	18.00	18.12	10.3	20.5	31.2	12.0	31.2	12.0	410
	MM	100	103	457	460	262	521	792	305	792	305	186
	IN	6	6.06	24.00	24.12	13.1	25.8	38.8	18.0	38.8	18.0	798
	MM	150	154	610	613	333	665	986	457	986	457	362
	IN	8	8.06	29.00	29.12	17.5	31.9	48.3	18.0	48.3	18.0	1351
	MM	200	205	737	740	445	810	1227	457	1227	457	613
	IN	10	10.06	33.00	33.12	21.8	38.0	57.4	18.0	57.4	18.0	2402
	MM	250	256	838	841	554	965	1458	457	1458	457	1090
	IN	12	12.06	38.00	38.12	24.4	43.9	65.2	24.0	65.2	24.0	3307
	MM	300	306	965	968	620	1115	1656	610	1656	610	1500
	IN	14	13.25	40.50	40.88	27.9	47.4	70.6	24.0	70.6	24.0	4295
	MM	350	337	1029	1038	709	1204	1793	610	1793	610	1948
	IN	16	15.25	44.50	44.88	30.0	52.8	77.6	24.0	77.6	24.0	5505
	MM	400	387	1130	1140	762	1341	1971	610	1971	610	2497
	IN	18	17.25	48.00	48.50	33.6	58.2	88.0	24.0	88.0	24.0	7582
	MM	450	438	1219	1232	853	1478	2235	610	2235	610	3439
	IN	20	19.19	52.00	52.50	37.9	66.2	97.9	30.0	97.9	30.0	11666
	MM	500	487	1321	1336	963	1681	2487	610	2487	610	5292
IN	24	25.00	57.00	/	48.8	83.4	116.6	30.0	116.6	30.0	19298	
MM	600	635	1448	/	1240	2118	2962	610	2962	610	8753	

# Liquid: Pressure Loss Curves for TCG Valves - 2" thru 14"

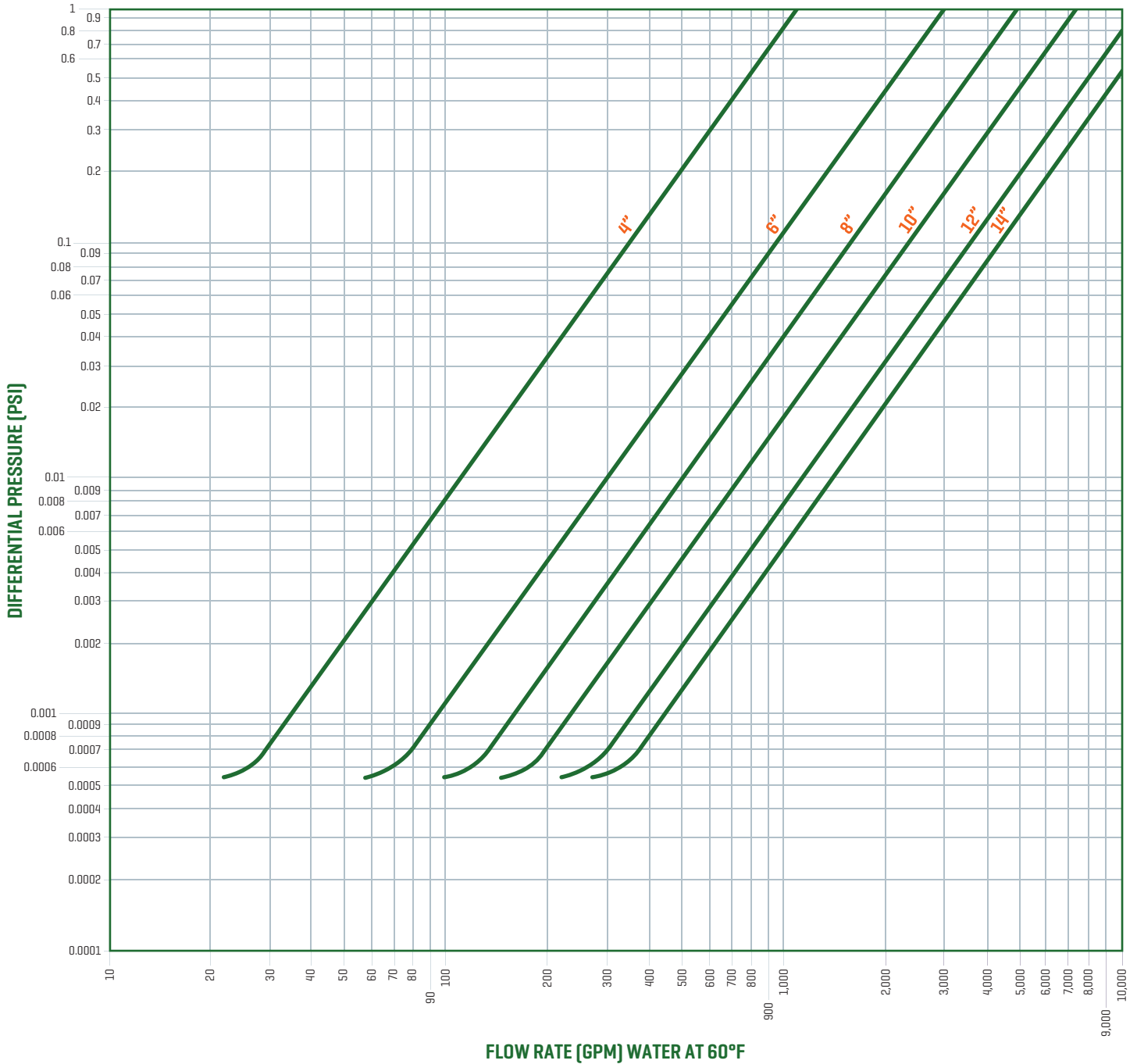

The above graph is based on simulations. Results may differ due to uncertainty within the pipeline or flow conditions. The formulas can be used to find the actual flow coefficient for a given condition of flow. The equations are valid only for incompressible flow.

Flow Coefficient for Fully Open Valves	
4	1,108
6	3,000
8	5,000
10	7,560
12	11,547
14	13,416

Glossary of Terms	
<b>Q</b>	Flow Rate, Liquids - GPM
<b>C<sub>v</sub></b>	Flow Coefficient
<b>P<sub>1</sub></b>	Inlet Pressure
<b>P<sub>2</sub></b>	Outlet Pressure
<b>ΔP</b>	Pressure Drop [P <sub>1</sub> - P <sub>2</sub> ]
<b>G</b>	Specific Gravity (Water = 1)

### Liquid (Incompressible Flow)

$$C_v = Q \sqrt{\frac{G}{\Delta P}} \quad Q = C_v \sqrt{\frac{\Delta P}{G}} \quad \Delta P = \left[ \frac{Q}{C_v} \right]^2 G$$



# Liquid: Pressure Loss Curves for TCG Valves - 16" thru 36"

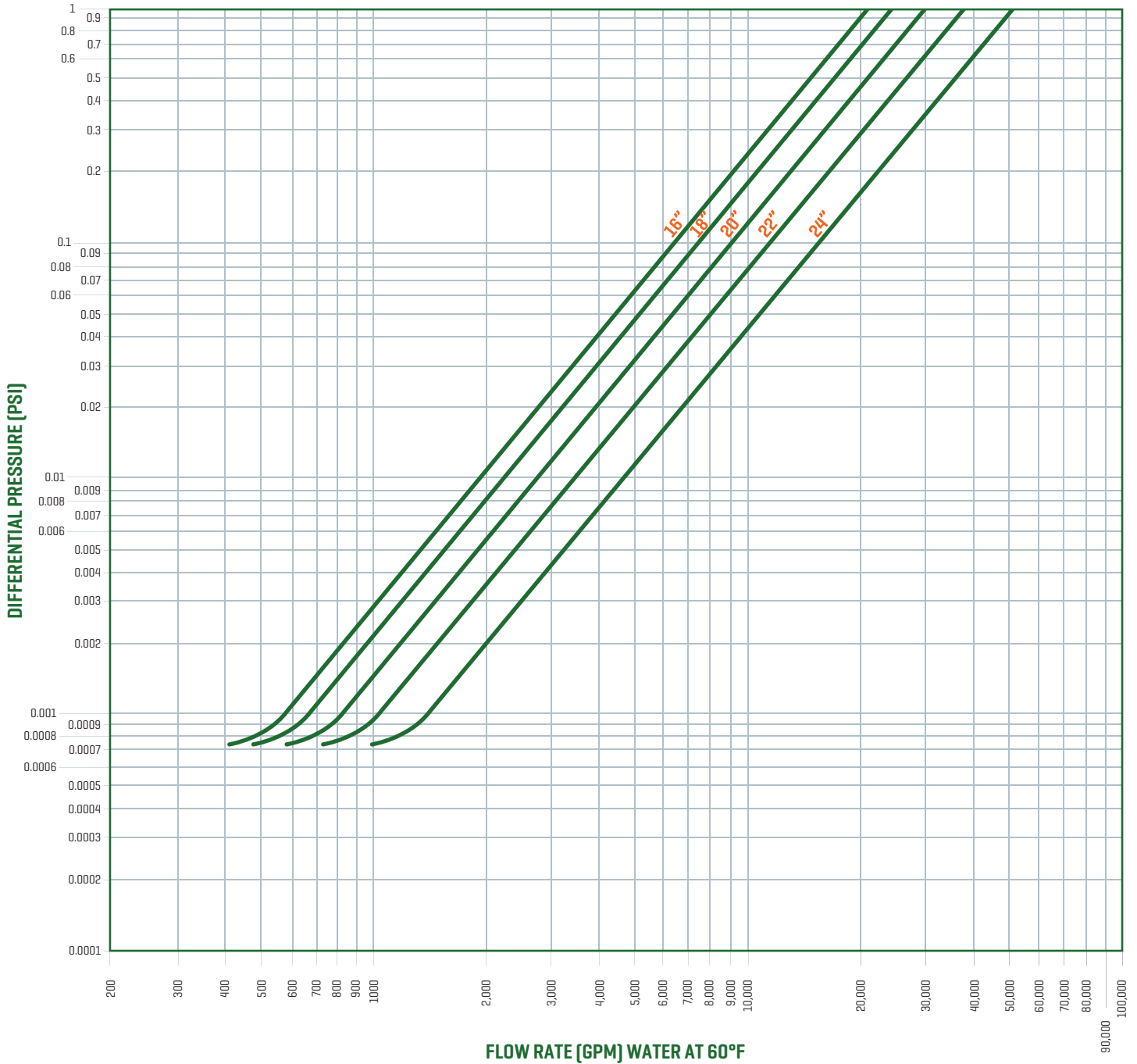

The above graph is based on simulations. Results may differ due to uncertainty within the pipeline or flow conditions. The formulas can be used to find the actual flow coefficient for a given condition of flow. The equations are valid only for incompressible flow.

Flow Coefficient for Fully Open Valves	
16	21,213
18	25,000
20	30,237
22	37,187
24	50,709

Glossary of Terms	
<b>Q</b>	Flow Rate, Liquids - GPM
<b>C<sub>v</sub></b>	Flow Coefficient
<b>P<sub>1</sub></b>	Inlet Pressure
<b>P<sub>2</sub></b>	Outlet Pressure
<b>ΔP</b>	Pressure Drop (P <sub>1</sub> - P <sub>2</sub> )
<b>G</b>	Specific Gravity (Water = 1)

### Liquid (Incompressible Flow)

$$C_v = Q \sqrt{\frac{G}{\Delta P}} \quad Q = C_v \sqrt{\frac{\Delta P}{G}} \quad \Delta P = \left[ \frac{Q}{C_v} \right]^2 G$$

# Expanding Gate Valve Operator Interface

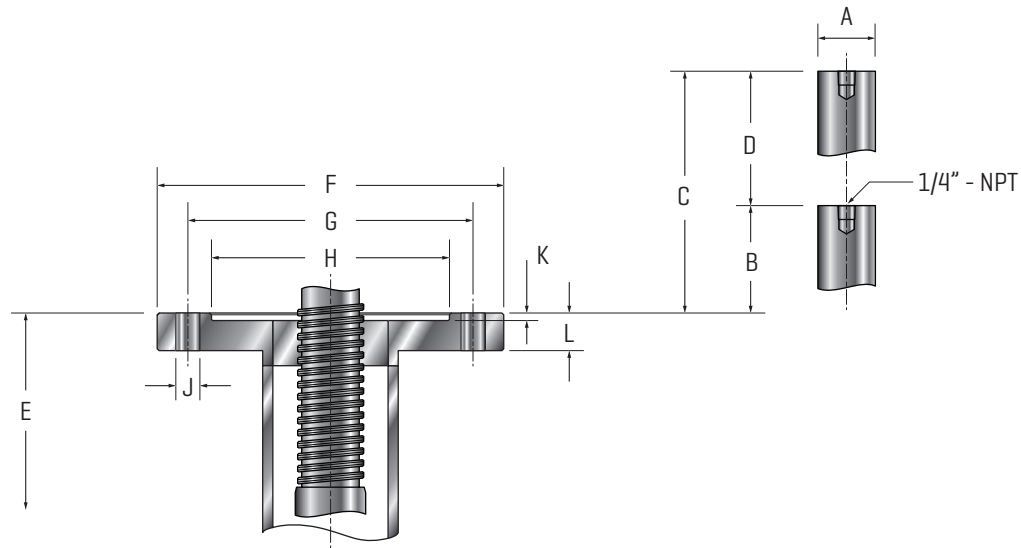

Valve Size	ANSI Class	Stem Thread * Double Lead Thread	Top of Stem Closed "B"	Top of Stem Open "C"	Total Travel "D"	To Ctr. of Valve "E"	Mtg. Plt. O.D. "F"	Bolt Circle "G"	Flg. Pilot Dia. "H"	Mounting Holes "J"	Flg. Pilot Depth "K"	Mtg. Plt Thickness "L"	ISO/MSS Mtg. Pattern
4	150	1-5TPI-2G-LH	3.90	8.85	4.95	16.90	5.00	4.02	2.79	4 X 0.50	0.15	0.43	FA10
4	300	1-5TPI-2G-LH	3.90	8.50	4.60	16.90	5.00	4.02	2.79	4 X 0.50	0.15	0.43	FA10
4	600	1-1/4-5TPI-2G-LH	4.17	9.05	4.88	20.5	2 7.00	5.50	3.98	4 X 0.75	0.18	1.00	FA14
4	900	1-1/4-5TPI-2G-LH	4.17	9.05	4.88	20.52	7.00	5.50	3.98	4 X 0.75	0.18	1.00	FA14
6	150	1-5TPI-2G-LH	3.94	10.72	6.78	21.70	5.00	4.02	2.79	4 X 0.50	0.15	0.43	FA10
6	300	1-5TPI-2G-LH	3.94	10.72	6.78	21.70	5.00	4.02	2.79	4 X .50	0.15	0.43	FA10
6	600	1-1/2-4TPI-2G-LH	4.54	11.39	6.85	25.78	7.00	5.50	3.98	4 X 0.75	0.18	1.00	FA14
6	900	1-1/2-4TPI-2G-LH	4.54	11.39	6.85	25.78	7.00	5.50	3.98	4 X 0.75	0.18	1.00	FA14
8	150	1-1/2-4TPI-2G-LH	4.47	13.60	9.13	27.88	6.75	5.50	3.98	4 X 0.69	0.18	0.70	FA14
8	300	1-1/2-4TPI-2G-LH	4.47	13.60	9.13	27.88	6.75	5.50	3.98	4 X 0.69	0.19	0.70	FA14
8	600	1-3/4-4TPI-2G-LH	5.34	14.72	9.38	31.94	8.00	6.50	5.15	4 X 0.81	0.23	1.15	FA16
8	900	1-3/4-4TPI-2G-LH	5.37	14.75	9.38	31.94	8.00	6.50	5.15	4 X 0.81	0.23	1.15	FA16
10	150	1-1/2-4TPI-2G-LH	5.11	16.29	11.19	33.54	6.75	5.50	3.98	4 X 0.69	0.18	0.70	FA14
10	300	1-1/2-4TPI-2G-LH	5.18	16.37	11.19	33.46	6.75	5.50	3.97	4 x 0.69	0.19	0.70	FA14
10	600	2-4TPI-2G-LH	6.08	17.79	11.71	37.99	8.50	6.50	5.15	4 X 0.88	0.25	1.13	FA16
10	900	2-4TPI-2G-LH	6.08	17.79	11.71	37.99	8.50	6.50	5.15	4 X 0.88	0.25	1.13	FA16
12	150	1-1/2-4TPI-2G-LH	5.44	18.55	13.11	39.11	6.75	5.50	3.98	4 X 0.69	0.18	0.70	FA14
12	300	1-1/2-4TPI-2G-LH	5.44	18.55	13.11	39.11	6.75	5.50	3.98	4 X 0.69	1.85	0.70	FA14
12	600	2-1/4-3TPI-2G-LH	6.11	19.72	13.61	43.88	11.50	10.00	7.90	8 X 0.75	0.25	1.25	FA25
12	900	2-1/4-3TPI-2G-LH	6.11	19.72	13.61	43.88	11.50	10.00	7.90	8 X 0.75	0.25	1.25	FA25
14	600	2-1/2-3TPI-2G-LH	6.75	21.89	15.14	47.52	11.50	10.00	7.90	8 X 0.75	0.25	1.25	FA25
14	900	2-1/2-3TPI-2G-LH	6.75	21.89	15.14	47.44	11.50	10.00	7.90	8 X 0.75	0.25	1.25	FA25
16	150	*1.5-0.20P-0.40L-ACME-2G-LH	6.02	22.52	16.50	47.89	6.75	5.50	3.96	4 X 0.69	0.15	0.70	FA14
16	300	*2.0-0.25P-0.50L-ACME-2G-LH	6.01	22.45	16.44	48.38	11.80	10.00	7.89	8 X 0.75	0.20	0.88	FA25
16	600	*2.5-0.40P-0.80L-ACME-2G-LH	6.42	23.07	16.65	52.25	12.00	10.00	7.90	8 X 0.75	0.25	1.25	FA25
16	900	*2.5-0.40P-0.80L-ACME-2G-LH	6.52	23.17	16.65	52.25	12.00	10.00	7.90	8 X 0.75	0.25	1.25	FA25
18	600	*3.0-0.40P-0.80L-ACME-2G-LH	8.71	27.74	19.03	58.55	12.00	10.00	7.90	8 X 0.75	0.25	1.25	AF25
18	900	*3.0-0.40P-0.80L-ACME-2G-LH	8.71	27.74	19.03	58.55	12.00	10.00	7.90	8 X 0.75	0.25	1.25	FA25
20	150	*2.0-0.25P-0.50L-ACME-2G-LH	5.93	26.17	20.24	57.99	8.25	6.50	5.14	4 X 0.81	0.23	0.75	FA16
20	300	*2.0-0.25P-0.50L-ACME-2G-LH	5.87	26.05	20.18	58.11	11.80	10.00	7.89	8 X 0.75	0.20	0.88	FA25
20	600	*3.25-0.40P-0.80L-ACME-2G-LH	9.37	30.33	20.96	65.70	14.00	11.73	9.10	8 X 0.88	0.25	1.39	FA30
20	900	*3.25-0.40P-0.80L-ACME-2G-LH	8.88	29.84	20.96	66.20	16.38	14.02	10.28	8 X 1.25	0.25	1.39	FA35
22	600	*3.25-0.40P-0.80L-ACME-2G-LH	9.43	32.74	23.31	72.41	16.38	14.02	10.28	8 X 1.25	0.25	1.25	FA35
24	150	*2.5-0.40P-0.80L-ACME-2G-LH	7.22	31.80	24.58	70.38	11.80	10.00	7.89	8 X 0.75	0.22	1.00	FA25
24	300	*2.5-0.40P-0.80L-ACME-2G-LH	7.04	31.54	24.50	70.63	13.75	11.73	9.07	8 x 0.88	0.22	1.00	FA30
24	600	*4.0-0.40P-0.80L-ACME-2G-LH	9.64	34.97	25.33	78.35	16.38	14.02	10.28	8 X 1.25	0.25	1.25	FA35
24	900	*4.0-0.40P-0.80L-ACME-2G-LH	9.15	34.47	25.33	78.80	18.50	15.98	11.84	8 X 1.38	0.33	1.25	FA40

# Slab Gate Valve Operator Interface

Valve Size	ANSI Class	Stem Thread * Double Lead Thread	Top of Stem Closed	Top of Stem Open	Total Travel	To Ctr. of Valve	Mtg. Plt. O.D.	Bolt Circle	Flg. Pilot Dia.	Mounting Holes	Flg. Pilot Depth	Mtg. Plt Thickness	ISO/MSS Mtg. Pattern
		"A"	"B"	"C"	"D"	"E"	"F"	"G"	"H"	"J"	"K"	"L"	
4	150	1-5TPI-2G-LH	3.80	8.56	4.76	16.63	5.00	4.02	2.79	4 X 0.50	0.15	0.43	FA10
4	300	1-5TPI-2G-LH	3.80	10.50	6.70	16.63	5.00	4.02	2.79	4 X 0.50	0.15	0.46	FA10
4	600	1-1/4-5TPI-2G-LH	4.39	9.29	4.90	20.52	7.00	5.50	3.98	4 X 0.75	0.18	1.00	FA14
4	900	1-1/4-5TPI-2G-LH	4.39	9.29	4.90	20.52	7.00	5.50	3.98	4 X 0.75	0.18	1.00	FA14
6	150	1-5TPI-2G-LH	3.70	10.45	6.75	21.63	5.00	4.02	2.79	4 X 0.50	0.15	0.43	FA10
6	300	1-5TPI-2G-LH	3.70	10.45	6.75	21.63	5.00	4.02	2.79	4 X 0.50	0.15	0.43	FA10
6	600	1-1/2-4TPI-2G-LH	5.01	11.86	6.85	25.78	7.00	5.50	3.98	4 X 0.75	0.18	1.00	FA14
6	900	1-1/2-4TPI-2G-LH	5.01	11.86	6.85	25.78	7.00	5.50	3.98	4 X 0.75	0.18	1.00	FA14
8	150	1-1/2-4TPI-2G-LH	4.30	13.13	8.83	27.69	6.75	5.50	3.98	4 X 0.69	0.18	0.70	FA14
8	300	1-1/2-4TPI-2G-LH	4.30	13.13	8.83	27.69	6.75	5.50	3.98	4 X 0.69	0.18	0.70	FA14
8	600	1-3/4-4TPI-2G-LH	5.50	14.88	9.38	31.94	8.00	6.50	5.15	4 X 0.81	0.23	1.15	FA16
8	900	1-3/4-4TPI-2G-LH	5.50	14.88	9.38	31.94	8.00	6.50	5.15	4 X 0.81	0.23	1.15	FA16
10	150	1-1/2-4TPI-2G-LH	5.10	15.98	10.88	33.14	6.75	5.50	3.98	4 X 0.69	0.19	0.70	FA14
10	300	1-1/2-4TPI-2G-LH	5.10	15.98	10.88	33.14	6.75	5.50	3.98	4 X 0.69	0.19	0.70	FA14
10	600	2-4TPI-2G-LH	6.40	17.90	11.50	37.99	8.50	6.50	5.15	4 X 0.88	0.25	1.13	FA16
10	900	2-4TPI-2G-LH	6.40	17.90	11.50	37.99	8.50	6.50	5.15	4 X 0.88	0.25	1.13	FA16
12	150	1-1/2-4TPI-2G-LH	5.10	18.10	13.00	38.63	6.75	5.50	3.98	4 X 0.69	0.19	0.70	FA14
12	300	1-1/2-4TPI-2G-LH	5.10	18.10	13.00	38.63	6.75	5.50	3.98	4 X 0.69	0.19	0.70	FA14
12	600	2-1/4-3TPI-2G-LH	7.00	20.25	13.25	43.88	11.50	10.00	7.90	8 X 0.75	0.25	1.25	FA25
12	900	2-1/4-3TPI-2G-LH	7.00	20.25	13.25	43.88	11.50	10.00	7.90	8 X 0.75	0.25	1.25	FA25
14	150	*1.5-0.20P-0.40L-ACME-2G-LH	5.10	19.39	14.29	41.42	6.75	5.50	3.98	4 X 0.69	0.19	0.70	FA14
14	300	*1.5-0.20P-0.40L-ACME-2G-LH	5.10	19.39	14.29	41.42	6.75	5.50	3.98	4 X 0.69	0.19	0.70	FA14
14	600	2-1/2-3TPI-2G-LH	7.30	22.30	15.00	47.44	11.50	10.00	7.90	8 X 0.75	0.25	1.25	FA25
14	900	2-1/2-3TPI-2G-LH	7.30	22.30	15.00	47.44	11.50	10.00	7.90	8 X 0.75	0.25	1.25	FA25
16	150	*1.5-0.20P-0.40L-ACME-2G-LH	6.10	22.28	16.18	46.73	6.75	5.50	3.98	4 X 0.69	0.19	0.70	FA14
16	300	*1.5-0.20P-0.40L-ACME-2G-LH	6.10	22.28	16.18	46.73	6.75	5.50	3.98	4 X 0.69	0.19	0.70	FA14
16	600	*2.5-0.40P-0.80L-ACME-2G-LH	7.20	23.70	16.50	52.25	12.00	10.00	7.90	8 X 0.75	0.25	1.25	FA25
16	900	*2.5-0.40P-0.80L-ACME-2G-LH	7.20	23.70	16.50	52.25	12.00	10.00	7.90	8 X 0.75	0.25	1.25	FA25
18	150	*1.75"-0.25P-0.50L-ACME-2G-LH	7.10	25.26	18.16	51.31	8.25	6.50	5.14	4 X 0.81	0.22	0.75	FA16
18	300	*1.75"-0.25P-0.50L-ACME-2G-LH	6.60	24.76	18.16	51.79	8.25	6.50	5.14	4 X 0.81	0.22	0.75	FA16
18	600	*3.0-0.40P-0.80L-ACME-2G-LH	9.30	27.96	18.66	58.18	12.00	10.00	7.90	8 X 0.75	0.25	1.25	FA25
18	900	*3.0-0.40P-0.80L-ACME-2G-LH	9.30	27.96	18.66	58.18	12.00	10.00	7.90	8 X 0.75	0.25	1.25	FA25
20	150	*2.0-0.25P-0.50L-ACME-2G-LH	5.80	26.04	20.24	57.21	8.25	6.50	5.15	4 X 0.81	0.25	0.75	FA16
20	300	*2.0-0.25P-0.50L-ACME-2G-LH	5.80	25.93	20.13	57.21	8.25	6.50	5.15	4 X 0.81	0.25	0.75	FA16
20	600	*3.25-0.40P-0.80L-ACME-2G-LH	9.91	31.01	21.10	65.70	14.02	11.73	9.10	8 X 0.88	0.25	1.38	FA30
20	900	*3.25-0.40P-0.80L-ACME-2G-LH	9.90	30.49	20.59	66.20	16.38	14.02	10.28	8 X 1.25	0.25	1.39	FA35
22	600	*3.25-0.40P-0.80L-ACME-2G-LH	10.10	33.41	23.31	70.54	16.38	14.02	10.28	8 X 1.25	0.25	1.25	FA35
24	150	*2.0-0.25P-0.50L-ACME-2G-LH	6.50	30.96	24.46	68.61	8.25	6.50	5.15	4 X 0.81	0.23	0.75	FA16
24	300	*2.0-0.25P-0.50L-ACME-2G-LH	5.90	30.36	24.46	69.24	8.25	6.50	5.15	4 X 0.81	0.23	0.75	FA16
24	600	*4.0-0.40P-0.80L-ACME-2G-LH	10.40	35.73	25.33	78.30	16.38	14.02	10.28	8 X 1.25	0.25	1.25	FA35

## Expanding Gate Thermal Relief System

With the expanding gate design, it is possible for Thermal Expansion to occur within the body cavity while the valve is in the closed position. A Thermal Relief system allows the body cavity to relieve into the upstream side of the valve.



SCV Valve installed Thermal Relief system on 16" Class 600 Thru Conduit Expanding Gate Valve.

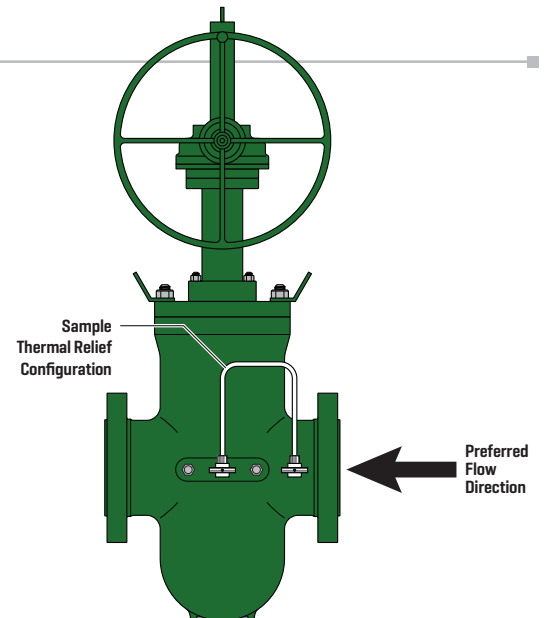





## Bolted Bonnet OS&Y Wedge Gate Valves - API 600

Class: 150 - 900/Sizes: 2" - 12"

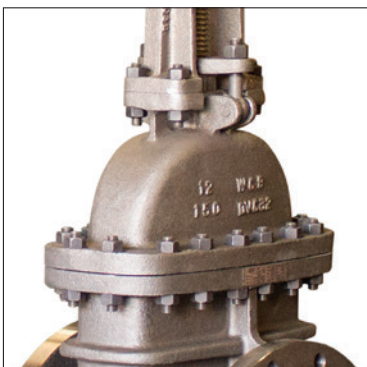

Design and Manufacturing Standards	
Basic Design	API 600 & ANSI/ASME B 16.34
Wall Thickness	ANSI/ASME B16.34
Face-to-Face Dimension	ANSI/ASME B16.10
Flange End Dimension	ANSI/ASME B16.5 (2" to 12")
Pressure/Temperature Rating I/A/W	ANSI/ASME B16.34
Inspection & Testing	API 598



For more information call us @ [281] 482-4728 or visit our website @ [www.scvvalve.com](http://www.scvvalve.com)

## Bolted Bonnet OS&Y Wedge Gate Valves - API 600

- Basic Design: API 600 & ANSI/ASME B 16.34
- Wall Thickness: ASME B 16.34
- Face-to-Face Dimensions: ANSI/ASME B16.10
- Flange End Dimensions: ANSI/ASME B16.5 [2" to 24"]
- Pressure/Temperature Rating I/A/W: ANSI/ASME B16.34
- Inspection & Testing: API 598

## Trim Configuration Options

- Solid Inconel stem
- Solid 316 SS stem
- Solid 17-4 PH stem
- Solid Inconel gate
- Inconel lined bore & seal area
- Solid stainless steel gate w/hardface overlay

**Note:** Not recommended for throttling applications.

**Note:** SCV reserves the right to change any technical design and dimensional data without prior notice. Please contact SCV to confirm all Dimensions and Data offered in this catalog.



# Bolted Bonnet OS&Y Wedge Gate Valves - API 600

[ Expanded View ]

No	Part	Material
1	Set Screw	Cast Steel
2	Handwheel Nut	Cast Steel
3	Handwheel	Malleable Iron
4	Stem Bushing Lock Nut	Cast Steel
5	Yoke Sleeve	A439 D-2
6	Grease Nipple	Cast Steel
7	Bonnet	A216 WCB
8	Gland Bolt Nut	A194 2H
9	Gland Bolt Pin	Cast Steel
10	Bonnet Bolt Nut	A194 2H
11	Bonnet Bolt	A193 B7
12	Gasket	304 Spiral Wound GR
13	Body	A216 WCB
14	Seat Ring	A105 + Stellite Hardface
15	Wedge	410 + Stellite Hardface
16	Backseat Bushing	A276 Type 410
17	Stem	410
18	Packing	Braided GR/Die Formed GR
19	Gland	A276 Type 410
20	Gland Flange	A216 WCB
21	Gland Bolt	A193 B7

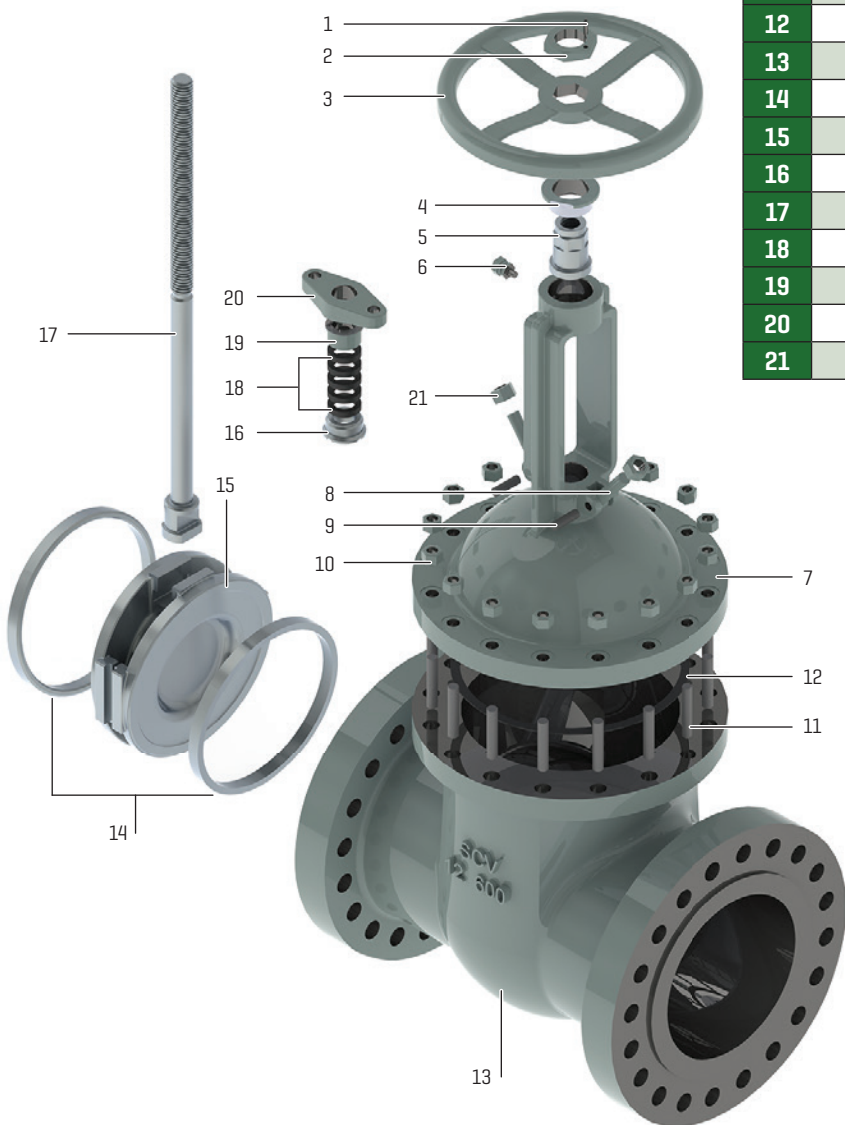



# Bolted Bonnet OS&Y Wedge Gate Valves

Size: 2" - 12"  
Class: 150 - 900

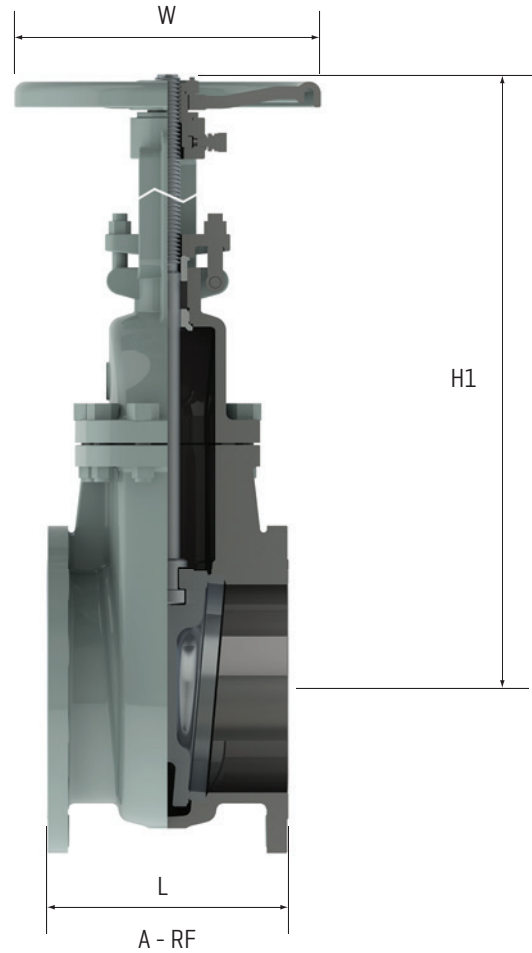

CLASS 150	Size	NPS	2	2.5	3	4	6	8	10	12
		DN	50	65	80	100	150	200	250	300
L	(RF)	IN	7.0	7.5	8.0	9.0	10.5	11.5	13.0	14.0
		MM	178	191	203	229	267	292	330	356
H1		IN	15.4	16.7	18.1	22.8	30.6	38.4	46.4	54.6
		MM	390	425	461	580	776	976	1178	1387
W		IN	7.9	7.9	7.9	9.8	11.8	14.0	17.7	17.7
		MM	200	200	200	250	300	355	450	450
WGT	(RF)	KG	22	25	30	45	85	134	202	290
		IB	44	46	62	92.6	161	244	399	584
WGT	(BW)	KG	20	21	28	42	73	111	181	265
CLASS 300	L	IN	8.5	9.5	11.12	12.0	15.9	16.5	18.0	19.75
		MM	216	241	282	305	404	419	457	502
H1		IN	16.2	17.7	19.0	23.7	32.0	40.2	48.8	56.8
		MM	412	450	483	601	813	1020	1239	1443
W		IN	7.9	7.9	8.8	9.8	14.0	15.7	17.7	19.7
		MM	200	200	224	250	355	400	450	500
WGT	(RF)	KG	29	40	48	74	142	220	327	496
		IB	52.9	77	82	141	269	379	512	862
WGT	(BW)	KG	24	35	37	64	122	172	232	391

CLASS 600	Size	NPS	2	2.5	3	4	6	8	10	12
		DN	50	65	80	100	150	200	250	300
L	(RF)	IN	11.5	13.0	14.0	17.0	22.0	26.0	31.0	33.0
		MM	292	330	356	432	559	660	787	838
L2	(RTJ)	IN	11.5	13.0	14.0	17.0	22.0	26.0	31.0	33.0
		MM	292	330	356	432	559	660	787	838
H1		IN	18.5	19.5	22.1	26.7	37.2	43.7	52.1	65.9
		MM	471	495	561	677	944	1110	1323	1675
W		IN	8.8	8.8	9.8	11.8	17.7	19.7	24.8	22.0
		MM	224	224	250	300	450	500	630	560
WGT	(RF)	KG	95	132	154	296	628	988	1499	2355
		IB	43	60	70	134	285	448	680	1068
WGT	(BW)	KG	62	99	132	229	452	690	1180	2145
		KG	28	45	60	104	205	313	535	973
CLASS 900	L	IN	14.5	16.5	15.0	18.0	24.0	29.0	33.0	38.0
		MM	368	419	381	457	610	737	838	965
L2	(RTJ)	IN	14.5	16.5	15.0	18.0	24.0	29.0	33.0	38.0
		MM	368	419	381	457	610	737	838	965
H1		IN	21.2	26.4	26.4	30.8	42.4	55.5	67.7	77.4
		MM	539	670	672	782	1076	1411	1720	1965
W		IN	11.8	11.8	14.0	15.7	22.0	17.7	22.0	22.0
		MM	300	300	355	400	560	450	560	560
WGT	(RF)	KG	181	342	364	384	999	1720	2752	3400
		KG	82	155	165	174	453	780	1248	1542
WGT	(BW)	KG	130	375	287	295	789	1378	2267	2844
		KG	59	170	130	134	358	625	1028	1290

# Auxiliary Bypass/Drain Boss Locations

## By-Passes

- Utilized in steam service to warm a flow system prior to opening the main valve.
- Utilized to balance line pressure on both sides of a main valve to reduce the torque demands.
- Cast steel valves can be fitted with all welded by-passes. \
- The standard by-pass configuration consists of a single OS&Y globe valve by-pass attached to the side of the main valve with the stems of both valves parallel.
- The piping and OS&Y globe by-pass valve have a pressure-temperature rating and corrosion resistance equal to or exceeding that of the main valve.
- A comprehensive arrangement drawing must be submitted by the customer for other by-pass configurations.

## Drains

- Cast steel valves can be fitted with drains at any of the locations shown.
- Standard drain connections consist of a drilled, tapped, and plugged hole at the specified location(s) by the customer.
- Other types of drains include welded or threaded nipples with/without shut-off valves, are available at the customer's request.

## Auxiliary Bypass/Drain Boss Locations

- Please refer to ASME B16.34 for exact auxiliary connection locations, sizes, and threading information.
- Each letter identifies a possible hole location for auxiliary connection(s) and are for reference only.
- Standard auxiliary connection hole sizes shall be drilled and tapped as follows, (unless specified otherwise by the customer):
  - 2" thru 4" utilizes a .50" hole
  - 5" thru 8" utilizes a .75" hole
  - 10" and larger utilizes a 1" hole

**Note:** Locations E, F, & K are on opposite side of valve.

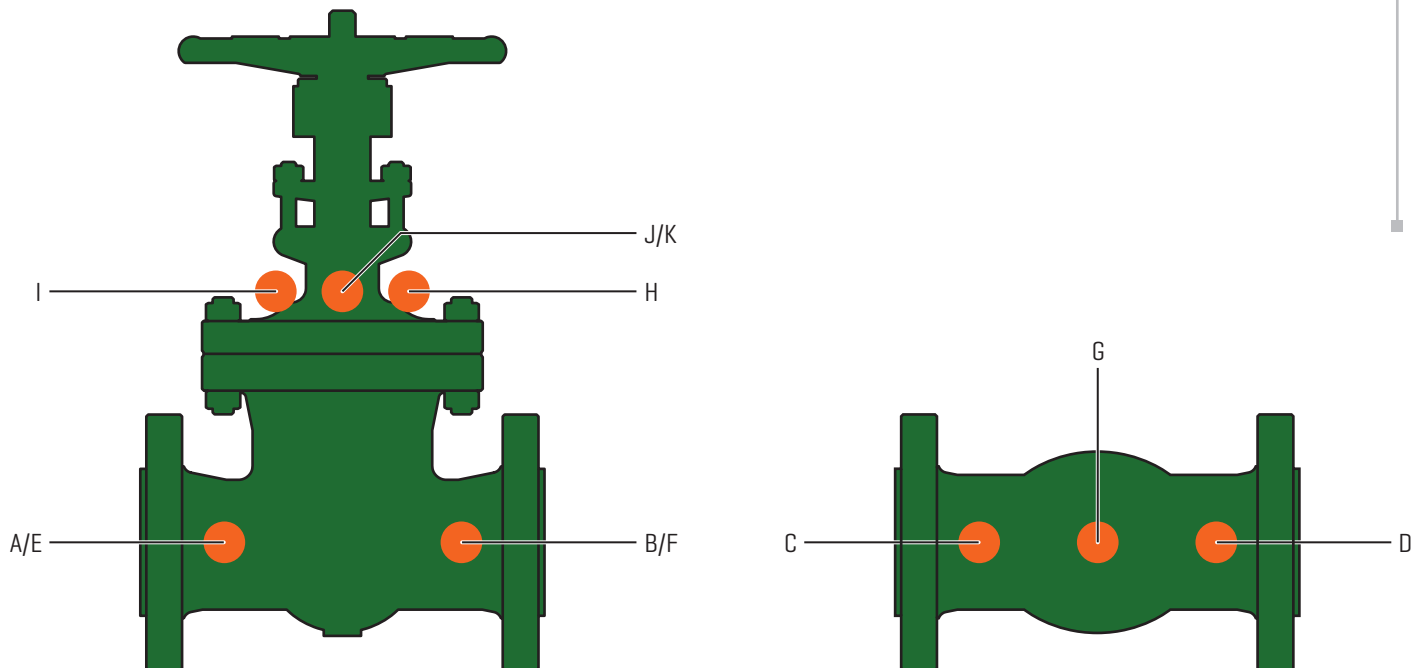

# Pressure Temperature Ratings - ASME B16.34 ■ ■ ■ ■ ■ ■ ■ ■ ■ ■

Note: Pressures in PSI

	Temp. F	A105	WCB	WCC	WC6	C5	C12	C12A	316	CF8M	F51	F53
	<b>150</b>	-20 to 100	285	285	290	290	290	290	290	275	275	290
200		260	260	260	260	260	260	260	235	235	260	260
300		230	230	230	230	230	230	230	215	215	230	230
400		200	200	200	200	200	200	200	195	195	200	200
500		170	170	170	170	170	170	170	170	170	170	170
600		140	140	140	140	140	140	140	140	140	140	140
650		125	125	125	125	125	125	125	125	125	125	125
700		110	110	110	110	110	110	110	110	110	110	110
750		95	95	95	95	95	95	95	95	95	95	95
800		80	80	80	80	80	80	80	80	80	/	/
850		65	65	65	65	65	65	65	65	65	/	/
900		50	50	50	50	50	50	50	50	50	/	/
950		35	35	35	35	35	35	35	35	35	/	/
1000		20	20	20	20	20	20	20	20	20	/	/
1050		/	/	/	20	20	20	20	20	20	/	/
1100		/	/	/	20	20	20	20	20	20	/	/
1150		/	/	/	20	20	20	20	20	20	/	/
1200		/	/	/	15	15	20	20	20	20	/	/
1250		/	/	/	/	/	/	/	20	20	/	/
1300	/	/	/	/	/	/	/	20	20	/	/	
1350	/	/	/	/	/	/	/	20	20	/	/	
1400	/	/	/	/	/	/	/	20	20	/	/	
1450	/	/	/	/	/	/	/	20	20	/	/	
1500	/	/	/	/	/	/	/	15	15	/	/	
<b>300</b>	Temp. F	A105	WCB	WCC	WC6	C5	C12	C12A	316	CF8M	F51	F53
	-20 to 100	740	740	750	750	750	750	750	720	720	750	750
	200	680	680	750	750	750	750	750	620	620	745	745
	300	655	655	730	720	730	730	730	560	560	665	665
	400	635	635	705	695	705	705	705	515	515	615	615
	500	605	605	665	665	665	665	665	480	480	580	580
	600	570	570	605	605	605	605	605	450	450	555	555
	650	550	550	590	590	590	590	590	440	440	545	545
	700	530	530	555	570	570	570	570	435	435	540	540
	750	505	505	505	530	530	530	530	425	425	530	530
	800	410	410	410	510	510	510	510	420	420	/	/
	850	320	320	320	485	485	485	485	420	420	/	/
	900	230	230	225	450	375	450	450	415	415	/	/
	950	135	135	135	320	275	375	385	385	385	/	/
	1000	85	85	85	215	200	255	365	365	365	/	/
	1050	/	/	/	145	145	170	360	160	160	/	/
	1100	/	/	/	95	100	115	300	305	305	/	/
	1150	/	/	/	65	60	75	225	235	235	/	/
	1200	/	/	/	40	35	50	145	185	185	/	/
1250	/	/	/	/	/	/	/	145	145	/	/	
1300	/	/	/	/	/	/	/	115	115	/	/	
1350	/	/	/	/	/	/	/	95	95	/	/	
1400	/	/	/	/	/	/	/	75	75	/	/	
1450	/	/	/	/	/	/	/	60	60	/	/	
1500	/	/	/	/	/	/	/	40	40	/	/	





# Terms & Conditions

## Quotation Validity

This quotation is valid for 30 days from the date quotation is sent. Validity on special metals, including Stainless Steel, is 14 days from the date the quotation is sent. All products offered from stock are subject to prior sale.

## Shipments

All items quoted are EXW our Dock - [Ex Works - SCV Valve Facility Santa Fe, Texas 77510] - unless otherwise noted and agreed to in writing. Shipment may be billed either third party billing to the buyer or freight collect. Shipment dates offered above are forecasted delivery lead times and are estimated from the date payment terms [acceptable to seller] are established, clarification is received on all technical information, and resolution of customer's written approval of drawings is received [when required]. The equipment quoted shall be packed in accordance with seller's standard packing procedure unless otherwise noted and agreed to in writing by the seller.

## Force Majeure

If in the case of an act of God, war, riot, fire, explosion, flood, or any other circumstances of whatsoever nature which are beyond the control of the seller and which in any way affect the ability of the seller to fulfill its delivery obligations, the delivery is hindered, impeded, or delayed the seller shall be exonerated from all responsibilities and reserves the right to postpone the delivery beyond the original schedule.

## Payment terms

All terms are to be negotiated. Credit cards accepted [Master Card, Visa, American Express].

## Purchase Orders

All buyer's purchase orders supplied to the seller are to be written in the English language.

## Prices

All prices quoted are in USD as per the preceding pricing schedule. The minimum order value is \$5,000.00 [five thousand dollars], unless otherwise agreed to by seller. If for some reason any items are changed or additions to the order required, seller reserves the right to adjust prices accordingly. All sales are subject to approval of seller's credit department. If buyer fails to meet the agreed upon and established commercial terms of the contract, the seller may with-hold all subsequent deliveries until such time that the original commercial terms of the contract have been met by the buyer [or subsequent commercial terms have been agreed upon by the seller with the buyer].

## Intellectual Property

All specifications, illustrations, drawings, certificates, and other particulars supplied by seller remain the intellectual property of the seller and should not be disclosed to any third party without the prior written consent of seller.

## Governing Law; Arbitration; Jurisdiction

The terms and conditions of this quotation and any subsequent purchase order shall be construed, interpreted, and performed exclusively according to the laws of the State of Texas, USA. The courts of such state shall have exclusive jurisdiction out of all controversies arising out of or in connection with this agreement. The parties consent that process may be served upon them in any such action by registered mail at the address stated for Buyer on its purchase order, and upon SCV Valve at the address noted above in Santa Fe, Texas, or personally within or without the State of Texas. Any legal action with respect to any agreement must be commenced within one year after the cause of action has accrued. The provisions of the Uniform Commercial Code as adopted by the State of Texas, and not under the United Nations Convention on Contracts for the International Sale of Goods, shall apply.

## Warranty

All seller's products are guaranteed against defects in workmanship for a period of twelve [12] months after being placed in service, but not exceeding eighteen [18] months after shipment, when products are properly installed per seller specifications and used within the service and pressure range for which they were manufactured. Full risk of loss shall pass to the buyer upon delivery at FOB point, or destination port in case of CIF. This guarantee is limited to the replacement of any valve parts/components found to be defective either in material or workmanship. This guarantee does not extend to costs of labor, freight, or any other consequential charges. The unauthorized use of third party components and workmanship in seller's products voids this warranty.

## Limitation of Liability

The liability of the seller under this agreement or with respect to any products supplied or services performed pursuant to this agreement, whether in contract, in tort, in strict liability or otherwise, shall not exceed the purchase price paid by the buyer with respect thereto. In no event will the seller be liable in contract, in tort, in strict liability or otherwise for any special, indirect, incidental, or consequential damages. This is including but not limited to loss of anticipated profits or revenues, loss of use, non-operation or increased expense of operation of equipment, cost of capital, or claims from customer or buyer for failure or delay in achieving anticipated profits or products.

## Cancellation

No contract may be canceled by the buyer except upon written notice to seller and upon payment to seller of all costs incurred by the contract arising out of, or in connection with, the contract. Export of goods covered hereby is subject to United States Customs Control. Standard stocking items will be subject to a twenty-five percent [25%] restocking and/or cancellation charge. Non-standard stocking items will be subject to a one-hundred percent [100%] restocking and/or cancellation charge.

## Cancellation Charge

The following indicates the rates of cancellation charge of contract value for project manufactured items and/or special engineered items at various stages of production:

- |  |                                  |
|--|----------------------------------|
| • <b>Time of cancellation: Order Acknowledgement and prior to Engineering engagement.</b>          | <b>Cancellation Charge: 10%</b>  |
| • <b>Time of cancellation: After start of engineering but prior to release to production.</b>      | <b>Cancellation Charge: 30%</b>  |
| • <b>Time of cancellation: After release to production but prior to completion of fabrication.</b> | <b>Cancellation Charge: 80%</b>  |
| • <b>Time of cancellation: After completion of fabrication.</b>                                    | <b>Cancellation Charge: 100%</b> |

## Return of Goods

No product shall be returned to seller without written authorization and shipping instructions having been obtained from seller. Products authorized for returns are to be shipped freight pre-paid to the SCV Valve Facility identified in writing, unless otherwise notified, and are subject to seller's standard re-stocking fees.

## Documentation

MTR's are available at no charge upon request. The seller's standard document package is per ISO 10474 3.1B requirements. Additional requested documentation is subject to charge.

## Inspection

The customer or his authorized representative may, with four [4] weeks prior notice given to seller, visually inspect products manufactured by seller. Such seller approved inspections will be carried out in accordance with seller's standard or seller approved customer inspection procedures. If any inspection or documentation requested by the customer is over and beyond the scope and criteria initially agreed to by the seller, any costs incurred by conducting such inspection or preparation of special documents shall be paid by the buyer prior to release of the items for shipment.

## Witness Hydro-testing

Witness hydro-testing is available at a cost. A scope of buyers inspection request is to be provided to seller at order placement. Late notice of such requested inspection is subject to additional costs. The cost associated with such witness hydro request is to be agreed on prior to any such testing taking place. Payment of this type of testing to be negotiated. Additionally, any costs associated with a third party inspector will not be at the sellers expense.

# Keepin' it clean!

## Harness Earth's Energy

As the demand for green energy skyrockets, sources for renewable energy plants increase daily. Geothermal Power Plants satisfy this demand very well with a minimal footprint and little impact on the environment. Geothermal energy is constantly produced within the earth and is a very clean, natural, reliable, and renewable energy source. The controlled capture and processing of this high-heat, pressurized release of thermal energy requires precision engineering and equipment.

Of the three types of Geothermal plants (Dry Steam, Flash Steam and Binary Cycle) high-quality, high-performance valves are critical components for successful geothermal energy conversion and delivery. All three geothermal power plants utilize heat in the form of steam, brine and/or heat transfer fluids to activate steam turbines which in turn produce electricity.

SCV manufactures a complete line of low-maintenance, dependable Thru Conduit Gate, Trunnion Ball, and Wedge Gate Geothermal Valves designed for this specific application and are made of materials that resist the inherent impurities contained in the process fluids and gasses, silica scaling (which can cause build-up, valve leakage or complete valve failure) and high pressures and heat.

The SCV Geothermal Valve Line has been proven to operate efficiently

at temperatures well above the required specifications (700°F/371°C) while offering minimal pressure loss.

Since 1972, the SCV brand has been committed to providing quality flow control products to the Power, Paper & Pulp, Oil & Gas, and Petro Chemical industries. As one of the largest valve manufacturers, SCV Valve's reputation is unparalleled for producing high quality commodity and specialty valves. Products range in sizes 1/2" - 48", in pressure classes from 150# - 2500# and are backed by timely deliveries and competitive prices.



**SCV VALVE**

**SALES, PROJECTS, ENGINEERING,  
MANUFACTURING, & WAREHOUSING**

3521 FM 646 Rd. North  
Santa Fe, TX 77510

**Phone:** [281] 482-4728

**Fax:** [281] 482-9728

**Email:** sales@scvvalve.com

**[www.scvvalve.com](http://www.scvvalve.com)**