

3-Piece Full Port Ball Valves

Carbon & Stainless Steel

Sizes .25" - 3"

Class 2000 W.O.G



Design and Manufacturing Standards

Basic Design	ANSI B 16.34S EN 12516-1
Thread End Dimension	ANSI B 1.201
Socket Weld End Dimension	ANSI B16.11
Inspection & Testing	API 598



3-Piece Full Port Ball Valves

2000 W.O.G.

Threaded Ends (ISO 5211 mounting pad), socket weld ends (ansi b 16.11), & butt weld ends (ansi 16.25)

- 1/4" thru 2": 2000 psi W.O.G.
- 2-1/2" thru 3": 1500 psi W.O.G.

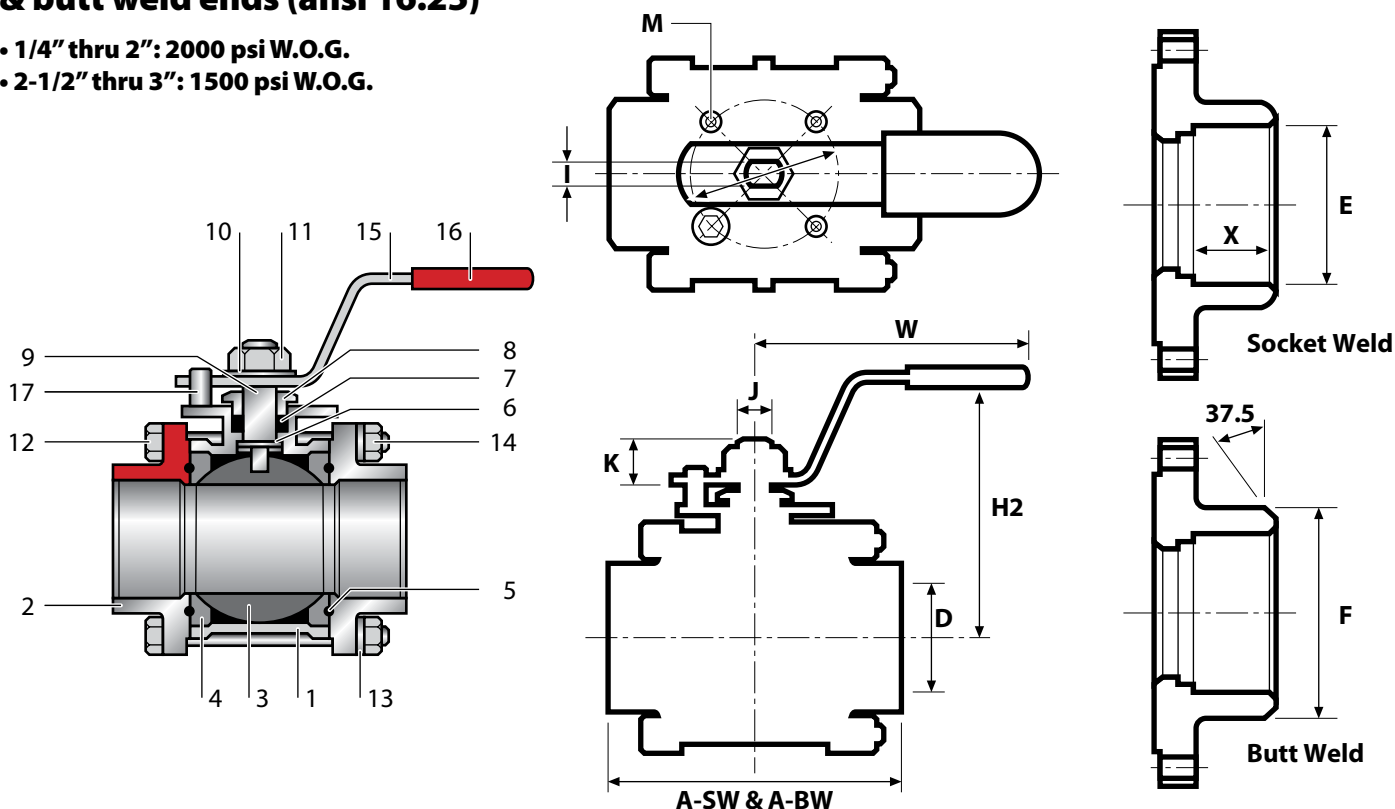

FEATURES

3-piece design for fast, economical in-line maintenance	Reinforced TFE seats increase durability
Strengthened construction secures 2000 psi rating	Bottom-loaded blow-out proof stem
Mounting pad complies with ISO 5211 for actuation ease and interchangeability	Re, Rp & G Threaded ends comply with BS 21/2779, JIS B-0203/ 0202, DIN259/2999, ISO 228-1, AS 1722.1/1722.2 are upon request
NPT threaded ends complied with ANSI B 1.20.1	Basic design complied with ANSI B16.34 & EN 12516-1
Tested according to API 598	

BILL OF MATERIAL

NO	NAME OF PART	STAINLESS STEEL	CARBON STEEL
1	BODY	ASTMA351-CF8M	ASTMA216-WCB
2	END CAP	ASTMA351-CF8M	ASTMA216-WCB
3	BALL	ASTMA351-CF8M/316	ASTMA351-CF8/304
4	SEAT	REINFORCED TFE	REINFORCED TFE
5	O-RING	PTFE	PTFE
6	STEM BUSHING	PTFE	PTFE
7	STEM PACKING	PTFE	PTFE
8	PACKING GLAND	AISI304	AISI304
9	STEM	ASTMA276-316	ASTMA276-304
10	HANDLE WASHER	AISI304	AISI304
11	STEM NUT	AISI304	AISI304
12	BONNET NUT	AISI304/GR. B8	CARBON STEEL/GR.B7
13	WASHER	AISI304/GR. 8	CARBON STEEL/ GR.2H
14	BODY STUD	AISI304	CARBON STEEL
15	HANDLE	AISI304	ZINC PLATED STEEL
16	HANDLE COVER	PVC	PVC
17	STOP SCREW	AISI304	CARBON STEEL

3-PIECE FULL PORT BALL VALVES

DIMENSIONS

		2000 PSI								1500 PSI	
VALVE SIZE	in	.25	.375	.5	.75	1	1.25	1.5	2	2.5	3"
	mm	6	10	13	19	25	32	38	51	64	76
D	in	0.43	0.49	0.59	0.79	1.00	1.26	1.50	1.97	2.56	3.15
	mm	11	12.5	15	20	25.4	32	38	50	65	80
A-SW	in	2.56	2.56	2.76	3.15	3.54	4.13	4.72	5.28	6.26	11.57
	mm	65	65	70	80	90	105	120	134	159	292
A-BW	in	2.56	2.56	2.80	3.23	3.62	4.33	5.00	5.91	7.20	8.27
	mm	65	65	71	82	92	110	127	150	183	210
E	in	.555	.690	.855	1.065	1.330	1.675	1.915	2.406	2.906	3.535
	mm	14.2	17.6	21.8	27.2	33.9	42.7	48.8	61.2	73.9	89.9
F	in	.57	.72	.88	1.09	1.37	1.70	1.94	2.42	2.95	3.54
	mm	14.6	18.3	22.4	27.8	34.7	43.3	49.3	61.4	75	90
I	in	0.20	0.20	0.20	0.24	0.31	0.31	0.31	0.31	0.47	0.47
	mm	5	5	5	6	8	8	8	8	12	12
J	in	0.31	0.31	0.31	0.39	0.47	0.47	0.55	0.55	0.79	0.79
	mm	8	8	8	10	12	12	14	14	20	20
K	in	0.37	0.37	0.47	0.54	0.70	0.70	0.71	0.71	1.14	1.14
	mm	9.5	9.5	12	13.7	17.7	17.7	18	18	29	29
G	in	1.42	1.42	1.42	1.42	1.65	1.65	1.97	1.97	2.76	2.76
	mm	36	36	36	36	42	42	50	50	70	70
H2	mm	M5	M5	M5	M5	M5	M5	M6	M6	M8	M8
M	in	2.13	2.13	2.24	2.46	2.70	2.91	3.56	3.92	5.06	5.49
	mm	54	54	57	62.5	68.5	74	90.5	99.5	128.5	139.5
W	in	5.31	5.31	5.31	5.31	6.50	6.50	6.89	6.89	9.57	9.57
	mm	135	135	135	135	165	165	175	175	243	243
X	in	.39	.39	.51	.59	.59	.59	.63	.67	.67	.67
	mm	10	10	13	15	15	15	16	17	17	17