

Dual Seal Expanding Plug Valves Cast Steel

Sizes 2" - 24"
Class 150 - 900



Design and Manufacturing Standards

Basic Design	API 6D
Shell Wall Thickness	API 6D
Face to Face Dimension	API 6D
Flange End Dimension	ANSI B16.5
Butt-Weld End Dimension	ANSI B16.25
Inspection & Testing	API 6D



Dual Seal Expanding Plug Valves

Class 150 - 900

2" - 24"

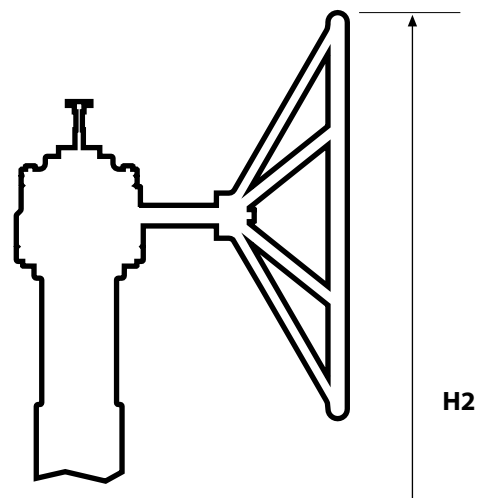
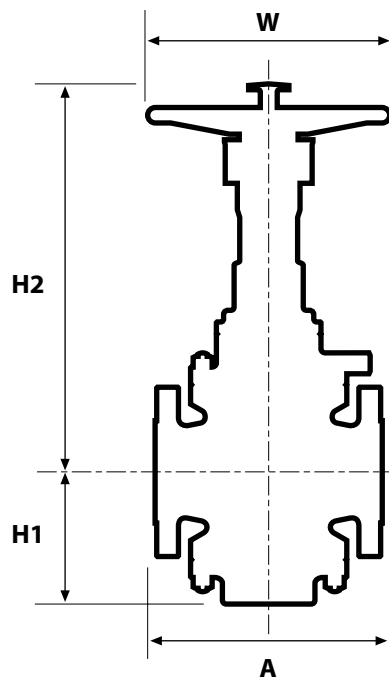
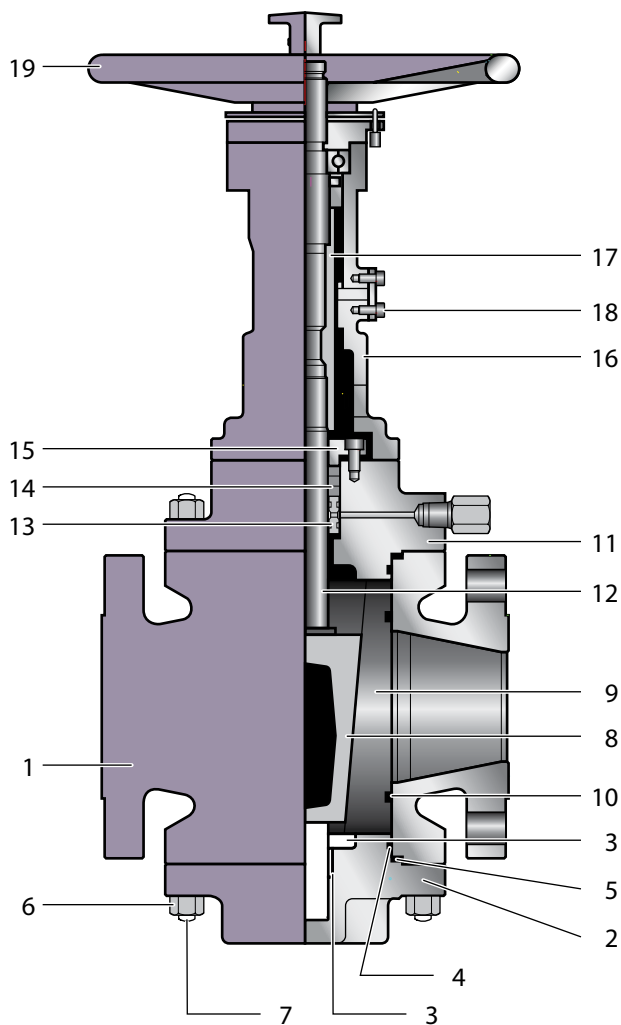

BILL OF MATERIAL

NO	NAME OF PART	ASTM	NO	NAME OF PART	ASTM
1	BODY	A216-WCB	11	UP COVER	A216-WCB
2	BONNET	A216-WCB	12	STEM	A182 F6a
3	BUSHING	95200	13	SEAL RING	A182 F6a
4	O-RING	FPM	14	PACKING	304+GRAPHITE
5	GASKET	304+GRAPHITE	15	PACKING GLAND	A216-WCB
6	STUD BOLT	A193 B7	16	YOKE	A216-WCB
7	NUT	A184 2H	17	BUSHING	A536 65-45-12+FPM
8	PLUG	A216-WCB	18	GUIDE PIN	17-4 PH
9	SLIP	A536 65-45-12+FPM	19	HANDWHEEL	DUCTILE IRON
10	SLIP SEAL	VITON	20	-	-

CLASS 150 - DUAL SEAL EXPANDING PLUG VALVES

DIMENSIONS & WEIGHTS

VALVE SIZE	in	2	3	4	6	8	10	12	14	16	18	20	24
	mm	51	76	105	152	203	254	305	356	406	457	508	610
A	in	7	8	9	10.5	11.5	13	14	15	16	17	32	36
	mm	179	203	229	267	292	330	356	381	406	432	813	914
H1	in	4.5	4.5	7	8.5	10.5	12	14.5	16	18	16	17	25.5
	mm	114	114	179	216	267	305	368	406	457	406	432	648
H2	in	12	12	15.5	17.5	22	23	31	32.5	39	36	37	44
	mm	305	305	394	445	559	584	787	826	991	914	940	1118
W	in	8	8	10	10	14	14	20	20	20	20	20	20
	mm	200	200	250	250	350	350	500	500	500	500	500	500
WGT	lb	64	76	140	214	436	532	844	1074	1488	2658	3326	6264
	kg	141	167	308	471	959	1170	1857	2363	3274	5848	7317	13781
1	in	.375	.375	.5	.5	.5	.5	.5	.5	.5	.5	.5	.5
	mm	10	10	13	13	13	13	13	13	13	13	13	13
2	in	.25	.25	.25	.25	.25	.25	.25	.5	.5	.5	.75	1
	mm	6	6	6	6	6	6	6	13	13	13	19	25

CLASS 300 - DUAL SEAL EXPANDING PLUG VALVES

DIMENSIONS & WEIGHTS

VALVE SIZE	in	2	3	4	6	8	10	12	14	16	18	20	24
	mm	51	76	105	152	203	254	305	356	406	457	508	610
A	in	8.5	11.125	12	15.875	16.5	18	19.75	30	33	36	39	52
	mm	216	283	300	403	419	450	502	750	838	900	991	1321
H1	in	4.5	4.5	7	9	11	12.5	16.5	14.5	14	20.5	24.5	25.5
	mm	114	114	178	229	279	318	419	368	356	521	622	648
H2	in	12	12	15.5	20.5	28	29	36.5	34.5	36.5	40.5	48	50.5
	mm	300	300	394	521	711	737	927	876	927	1029	1219	1283
W	in	8	8	10	14	20	20	20	20	20	20	32	32
	mm	200	200	250	350	500	500	500	500	500	500	800	800
WGT	lb	78	102	162	348	665	888	1414	1990	2662	3550	4155	8150
	kg	34	46	74	158	302	404	653	905	1210	1614	1889	3705
1	in	.375	.375	.5	.5	.5	.5	.5	.5	.5	.5	.5	1
	mm	10	10	13	13	13	13	13	13	13	13	13	25
2	in	.25	.25	.25	.25	.25	.25	.25	.5	.5	.5	.5	1
	mm	6	6	6	6	6	6	6	13	13	13	13	25

CLASS 600 - DUAL SEAL EXPANDING PLUG VALVES

DIMENSIONS & WEIGHTS

VALVE SIZE	in	2	3	4	6	8	10	12	14	16	20	24
	mm	51	76	102	152	203	254	305	356	406	508	610
A	in	11.5	14	17	22	26	31	33	35	39	47	55
	mm	292	356	432	559	660	787	838	889	991	1194	1397
H1	in	5.5	6	7	9	11	16	17	19.5	19.5	23.5	26
	mm	140	152	178	229	279	406	432	495	495	597	660
H2	in	15.5	16	19	26	27	36.5	38	47	57	66	72
	mm	393	406	482	660	685	927	965	1194	1447	1676	1828
W	in	11.8	11.8	15.75	18.1	18.1	23.6	23.6	23.6	23.6	23.6	23.6
	mm	300	350	400	460	460	600	600	600	600	600	600
WGT	lb	100	149	276	696	1102	1974	2532	4100	4300	9500	15000
	kg	45	68	125	316	501	897	1151	1864	1955	4318	6818
1	in	.5	.5	.5	.5	.5	.5	.5	.5	.5	1	1
	mm	13	13	13	13	13	13	13	13	13	25	25
2	in	.25	.25	.25	.25	.25	.5	.5	.5	.5	1	1
	mm	6	6	6	6	6	13	13	13	13	25	25

CLASS 900 - DUAL SEAL EXPANDING PLUG VALVES

DIMENSIONS & WEIGHTS

VALVE SIZE	in	2	3	4	6	8	10
	mm	51	76	102	152	203	254
A	in	14.5	15	18	24	29	33
	mm	368	381	457	609	736	838
H1	in	7	8	10	11.5	16.5	21
	mm	178	203	254	292	419	553
H2	in	19	20	22	26	37	51.5
	mm	482	508	558	660	940	1308
W	in	12.2	12.2	18.1	18.1	23.6	23.6
	mm	310	310	460	460	600	600
WGT	lb	180	235	397	975	1440	3600
	kg	82	107	180	975	655	1636
1	in	.5	.5	.5	.5	.5	.5
	mm	13	13	13	13	13	13
2	in	.25	.25	.5	.5	.5	.5
	mm	6	6	13	13	13	13